

**Pharmacy Reengineering (PRE)
Inbound ePrescribing (IEP) 2.0
VistA Patch # PSO*7.0*467
User Guide**



December 2017

Version 2.0

Department of Veterans Affairs

Office of Information and Technology (OI&T)

Revision History

Date	Revision	Description	Author
12/05/2017	2.0	New Document, Baseline release	Technatomy

Table of Contents

Unit 1. Introduction to Inbound ePrescribing	8
Organization of the Inbound ePrescribing User Guide	8
Inbound ePrescribing Overview	8
Purpose.....	8
Overview	8
User Interfaces	11
Inbound ePrescribing Web-Based Application.....	11
VistA Outpatient Pharmacy eRx Holding Queue	11
Inbound ePrescribing Workflow	11
Inbound ePrescribing Architecture	14
Roles and Capabilities.....	15
Acronyms and Abbreviations	18
Unit 2. Inbound ePrescribing Web-Based Application.....	20
Inbound ePrescribing Web-Based Application Overview	20
Purpose.....	20
Access Requests	20
Accessing the Application	20
Screen Navigation and Description.....	22
Inbound eRx Homepage	23
Pharmacy Management	23
Track/Audit.....	25
Reports.....	25
User Management.....	26
Help Page	26
Inbound ePrescribing Web-based Application Capabilities.....	27
Pharmacy Management	27
Searching for a Pharmacy	27
Adding a Pharmacy	27
Updating a Pharmacy.....	27
Disable eRx	28

Temporarily Disable eRx.....	28
Enable eRx	30
Track/Audit	30
Searching for and Tracking/Auditing a Prescription.....	30
Export Search Results	34
Inbound/Outbound Message Detail	34
NewRx Message	35
Error Messages	36
Verify Messages	37
Status Messages	38
Reports.....	39
Summary Report.....	39
Export Reports	42
User Management	42
Add New User	42
Modify User Roles	44
Delete Users.....	45
Help Desk.....	45
Unit 3. VistA Outpatient Pharmacy eRx Holding Queue	46
Purpose	46
Setting Up Default eRx Clinic (Optional).....	46
Accessing the eRx Holding Queue	46
eRx Holding Queue List View	47
eRx Holding Queue Summary Screen.....	48
eRx Actions	50
Patient-Level Record Lock	51
Manual Validation	51
Validate Patient	52
Patient Auto-Match in the Processing Hub	52
Patient Manual Validation Screen Overview	53
Edit Patient.....	55
Accept Patient Validation.....	55

Automatic Patient Validation	56
Validate Provider	57
Provider Auto-Match in the Processing Hub.....	58
Provider Manual Validation Screen Overview	58
Edit Provider	58
Accept Provider Validation	59
Automatic Provider Validation	61
Validate Drug/SIG	62
Drug Auto-Match in the Processing Hub.....	62
Drug/SIG Manual Validation Screen Overview	63
Edit Drug/SIG	64
Additional Field-level Information:	66
Accept Drug/SIG Validation	67
Accepting eRxS in the eRx Holding Queue	68
Rejecting eRxS in the eRx Holding Queue.....	69
Printing in the eRx Holding Queue.....	70
Placing eRxS on Hold in the eRx Holding Queue	72
Un Hold eRx in the eRx Holding Queue	73
Removing eRxS in the eRx Holding Queue	75
Searching and Sorting in the eRx Holding Queue.....	76
Searching eRxS.....	76
Search eRx – Patient Name	76
Search eRx – Date of Birth	79
Search eRx – Received Date Range	79
Search eRx – Provider Name	80
Search eRx – ERX Status	82
Search eRx – Drug Name.....	83
Sorting eRxS.....	83
Sort eRx – Patient Name	85
Sort eRx – Date of Birth	85
Sort eRx – Received Date Range	85
Sort eRx – Provider Name	86

Sort eRx – eRx Status.....	86
Sort eRx – Drug Name.....	87
Complete Orders from OERR and Patient Prescription Processing	87
Help Desk	90
Appendix A. Holding Queue Status Codes & Descriptions	91
Appendix B. NCPDP Error Codes	93

List of Figures

Figure 1-1: Inbound ePrescribing Web-based Application	11
Figure 1-2: Inbound ePrescribing Process Flow.....	12
Figure 1-3: Inbound ePrescribing Architecture	14
Figure 2-1: VA Single Sign-on.....	20
Figure 2-2: Select a Certificate	21
Figure 2-3: Active Client Login	21
Figure 2-4: Warning Message	21
Figure 2-5: Home Screen.....	22
Figure 2-6: Web-Based Application Screen Layout.....	22
Figure 2-7: Home Screen.....	23
Figure 2-8: Pharmacy Management Screen	24
Figure 2-9: Track/Audit Screen	25
Figure 2-10: Reports Screen	25
Figure 2-11: User Management Screen	26
Figure 2-12: Help Screen	26
Figure 2-13: Help Page	26
Figure 2-14: Narrow Search by VISN	27
Figure 2-15: NCPDP ID Column Hyperlinks.....	28
Figure 2-16: Edit Pharmacy Screen	29
Figure 2-17: eRx Enabled Drop Down.....	29
Figure 2-18: Update Pharmacy Information	30
Figure 2-19: Enable/Disable Pharmacy.....	30
Figure 2-20: Track/Audit Search Criteria	31
Figure 2-21: Track/Audit eRx Search.....	32
Figure 2-22: Search Results	32
Figure 2-23: Export Search Results.....	34
Figure 2-24: Track/Audit Export Prompt (after clicking Export Buttons)	34
Figure 2-25: Track/Audit Grid View.....	34
Figure 2-26: eRx Reference # Hyperlink.....	35
Figure 2-27: Track/Audit Detail Screen for NewRx Message Type	35
Figure 2-28: NewRx Detail Screen: Available Actions	36
Figure 2-29: Track/Audit Detail Screen for Error Message Type	36
Figure 2-30: Track/Audit Detail Screen - Return to Search/Print Buttons	37
Figure 2-31: Track/Audit Screen Criteria - Sent or Received Dropdown.....	37
Figure 2-32: Track/Audit Detail Screen Status/Verify Message Type	37
Figure 2-33: Track/Audit Detail Screen Status Message Type	38
Figure 2-34: Summary Report Dropdown.....	39
Figure 2-35: Reports Screen Filter Criteria – Select VISN from Dropdown.....	39

Figure 2-36: Reports Screen Filter Criteria - Select Station ID from Dropdown	40
Figure 2-37: Reports Screen Filter Criteria - Select Date Range.....	40
Figure 2-38: Run Report Button	41
Figure 2-39: Summary Report Results	41
Figure 2-40: Export Report Buttons.....	42
Figure 2-41: Summary Report Export Prompt (after clicking Export Button).....	42
Figure 2-42: Add User - User ID, First Name, Last Name	43
Figure 2-43: Add User - Select User Roles	43
Figure 2-44: Add User - Save and Cancel.....	44
Figure 2-45: Select User Roles.....	44
Figure 3-1: Complete Orders from eRx Menu Option	47
Figure 3-2: eRx Holding Queue List.....	47
Figure 3-3: eRx Holding Queue List View.....	48
Figure 3-4: Summary Screens.....	49
Figure 3-5: Patient-Level Record Lock	51
Figure 3-6: Summary Screen Actions	51
Figure 3-7: Validate Patient	52
Figure 3-8: Patient Validation Screen Display - Patient Not Validated/ Not Auto Matched	53
Figure 3-9: Patient Validation Screen Display - Patient Not Validated / Patient Auto Matched	54
Figure 3-10: Patient Validated	54
Figure 3-11: Edit Patient on a VistA Match.....	55
Figure 3-12: Mismatch Warning Message	55
Figure 3-13: Confirm Acceptance of Patient Validation	56
Figure 3-14: Patient Validation Complete: Summary Screen Indicator	56
Figure 3-15: Automatic Patient Validation.....	57
Figure 3-16: Apply Patient Validation to Other eRx.....	57
Figure 3-17: Summary Screen Action - Validate Provider.....	57
Figure 3-18: Provider Not Auto Matched / Not Validated.....	58
Figure 3-19: Modify Current VistA Provider	59
Figure 3-20: Select Provider Warning Message.....	59
Figure 3-21: Before Provider Validation (Validate Provider Screen)	60
Figure 3-22: After Provider Validation (Validate Provider Screen)	60
Figure 3-23: After Provider Validation (Summary Screen)	61
Figure 3-24: Automatic Provider Validation	61
Figure 3-25: Validate Drug / SIG.....	62
Figure 3-26: Drug Validation Screen Display - VistA Drug Not Validated / Not Auto Matched	63
Figure 3-27: Drug Validation Screen Display - VistA Drug Matched / Not Validated	64
Figure 3-28: eRx Display During Edit Drug / SIG	65
Figure 3-29: Confirm Acceptance of Drug / SIG Validation.....	67
Figure 3-30: Drug / SIG Validation Complete (Validate Drug / SIG Screen).....	67
Figure 3-31: Drug / SIG Validation Complete (Summary Screen)	68
Figure 3-32: Accept eRx - Sample Validation Errors	68
Figure 3-33: Accept eRx	69
Figure 3-34: eRx Sent to Pending Outpatient Orders	69
Figure 3-35: Rejecting an eRx	70
Figure 3-36: Reject Message in Processing Hub	70
Figure 3-37: Print Display of eRx	71
Figure 3-38: Hold eRx	72

Figure 3-39: Select Hold Reason Code.....	73
Figure 3-40: Hold Status and Reason	73
Figure 3-41: Hold Status in Status Column	73
Figure 3-42: Un Hold eRx.....	74
Figure 3-43: Removing an eRx.....	75
Figure 3-44: Search Queue Action.....	76
Figure 3-45: Search Criteria - Patient Name	77
Figure 3-46: Patient Name Search	77
Figure 3-47: Search eRx by Patient Name Results	78
Figure 3-48: Search Criteria - Date of Birth	79
Figure 3-49: Search eRx by Date of Birth Results	79
Figure 3-50: Search Criteria - Received Date Range	80
Figure 3-51: Enter Beginning and Ending Date	80
Figure 3-52: Search eRx by Received Date Range	80
Figure 3-53: Search Criteria - Provider Name	81
Figure 3-54: Enter Provider Name.....	81
Figure 3-55: Search eRx by Provider	81
Figure 3-56: Search Criteria - eRx Status	82
Figure 3-57: Search by eRx Status	82
Figure 3-58: Search Criteria - Drug Name	83
Figure 3-59: Search eRx by Drug Name	83
Figure 3-60: Sort Entries Action.....	84
Figure 3-61: Sort by Patient Name	85
Figure 3-62: Sort by Received Date Range	86
Figure 3-63: Sort Criteria - Sort by Provider.....	86
Figure 3-64: Hidden Option EP / Print Display of eRx	87
Figure 3-65: eRx Display in Pending Queue - Page 1	88
Figure 3-66: eRx Order in Pending Queue – Page 2	88
Figure 3-67: eRx Order in Pending Queue - Page 3.....	89
Figure 3-68: eRx Order in Pending Queue - Page 4.....	89
Figure 3-69: eRx Order in Pending Queue - Page 5.....	90

List of Tables

Table 1: Inbound ePrescribing Web-Based Application User Roles & Capabilities.....	15
Table 2: VistA OP Inbound eRx Holding Queue User Roles & Capabilities.....	17
Table 3: Acronyms and Abbreviations	18
Table 4: Track/Audit Search Criteria Descriptions	31
Table 5: Search Results Fields & Descriptions.....	32
Table 6: Summary Report Columns.....	41
Table 7: Holding Queue Status Codes & Descriptions.....	91
Table 8: NCPDP Error Codes	93

Unit 1. Introduction to Inbound ePrescribing

This unit provides the purpose and organization of the Pharmacy Reengineering (PRE) Inbound ePrescribing (IEP) solution and a list of acronyms and abbreviations.

Organization of the Inbound ePrescribing User Guide

The PRE IEP user guide is comprised of the following three sections:

- [Unit 1 – Introduction to Inbound ePrescribing](#): Discusses general PRE Inbound ePrescribing information. Also included is a list of acronyms and abbreviations
- [Unit 2 – Inbound ePrescribing Web-Based Application](#): Outlines the IEP Web-based application and capabilities, including Pharmacy Management, Track/Audit, Reports, and User Management functions
- [Unit 3 – VistA Outpatient Pharmacy eRx Holding Queue](#): Discusses the VistA OP eRx Holding Queue and capabilities, including eRx validation, search, sort, hold, acceptance, remove, and rejection

Inbound ePrescribing Overview

The PRE IEP functionality addresses a longstanding need for the Department of Veterans Affairs (VA) to be able to receive and process prescriptions from external providers. This enhancement moves the VA towards increased efficiency and improved customer satisfaction.

Purpose

The purpose of PRE IEP is to enable VA to receive and subsequently process electronic prescriptions (eRx,s) from outside of VA. This user guide serves as a guide and useful reference for VA Pharmacists, Pharmacy Technicians/Assistants, Systems Administrators, Managers, and other VA staff to assist in accessing, navigating, and performing tasks associated with the PRE IEP Web-based application and the Veterans Health Information Systems and Technology Architecture (VistA) Outpatient Pharmacy (OP) eRx Holding Queue.

Overview

In order to improve on its ability to deliver Veterans their medications as quickly and efficiently as possible, the Veterans Health Administration (VHA), Patient Care Services (PCS), and Pharmacy Benefits Management (PBM) requested a new capability as part of the PRE program to receive inbound eRxS from an external provider (e.g., a doctor not associated with the VA, medical staff at a Department of Defense (DoD) military treatment facility, etc.).

Overall, PRE IEP provides:

- Improved efficiency. More efficient use of VA pharmacy resources and non-VA provider resources based on:
 - Fewer transcribing/translation errors
 - Clear/error-free communications

- Time saved not having to communicate back and forth regarding the content of a prescription
- Improved Veteran/beneficiary satisfaction. Makes the existing manual processing easier, more efficient, and more effective through the automation of the prescription process by:
 - Reducing the risk of loss of paper R_xs
 - Enabling more secure communication of R_x data
 - Providing timelier dispensing of R_xs prescribed by non-VA providers
- Improved patient safety: Reduces transcription errors
- Improved data accuracy: Provides enhanced functionality within VistA OP that improves the accuracy and use of the data it collects

By automating data transmission from providers to the VA, and between other pharmacies, the need for VA pharmacy personnel to manually input R_x data from non-VA providers is largely eliminated, reducing the chance for data to be entered incorrectly or missed.

Specific elements of what is included in PRE IEP include:

- Receiving and processing inbound eR_xs, where “inbound” refers to the ordering of medication or medical related supplies for a VA patient by a non-VA provider; to be filled at a VA pharmacy.
- Pharmacy Service is not responsible for filling prescriptions for non-expendable medical equipment.
- Pharmacy Service may dispense refills for expendable supplies upon receipt of requests from patients with continuing eligibility for a period not to exceed one year from the date of the last signed order.
- Expendable stock items may include: catheters, colostomy sets, ileostomy sets and/or supplies, plastic and rubber gloves, skin preparations and powders, urinal bags and drainage supplies, incontinence supplies, etc.
- Electronically receiving and processing outpatient prescriptions only, including prescriptions created for a VA patient upon discharge from a non-VA hospital to be filled on an outpatient basis by a VA pharmacy.
- Receiving and processing inbound eRx from non-VA providers that currently prescribe medications and medical-related supplies for Civilian Health and Medical Program of the VA (CHAMPVA) beneficiaries and which are currently handled by the Meds by Mail (MbM) program.
- Sending outbound electronic notifications from a VA pharmacy that received an inbound eRx, to the non-VA provider that originally sent the eR_x.

The following areas are not included in PRE IEP:

- VA providers generating eR_xs at one VA Medical Center (VAMC) location to be electronically transmitted to and processed by (filled, dispensed, etc.) a different VAMC location’s pharmacy.

- Initiating outbound eRxS (generation of an eR_x by a VA provider to be filled at a non-VA pharmacy).
- Electronic receipt and processing of any VA or non-VA inpatient medication orders.
- Electronic receipt and processing of any VA or non-VA orders for Durable Medical Equipment (DME), such as wheel chairs.
- Electronic receipt and processing of R_x refill requests from a VA patient's non-VA Electronic Health Record (EHR) system.
- Electronic transfers of prescriptions from any non-VA pharmacy to a VA pharmacy.
- Electronic transfers of prescriptions from a VA pharmacy to a non-VA pharmacy.
- The ability for the VA to request an Electronic Prior Authorization (ePA) form and authorization from a provider.

The following are out of an eR_x user's control, which requires validation by Pharmacists.

- Patient: eR_xS can be sent for any patient, including Veterans or non-Veterans.
- Provider: eR_xS can be sent by any provider, whether VA authorized or not.
- Drugs: VA has no control over the drug, nor the name of drug sent to VA.
- SIG: VA has no control over directions that are sent to VA.
- All information coming to the VA is controlled by the EHR system which is what the provider is using to send information to the VA. VA has no control over the process.

User Interfaces

There are two user interfaces associated with IEP, including the following:

- IEP Web-Based Application
- VistA Outpatient Pharmacy Module eRx Holding Queue

Inbound ePrescribing Web-Based Application

The IEP Web-based application is used by Pharmacy Technicians, Administrators, Pharmacy Managers, and PBM Admin personnel. It has tab displays for the following:

- Home
- Pharmacy Management
- Track/Audit
- Reports
- User Management
- Help

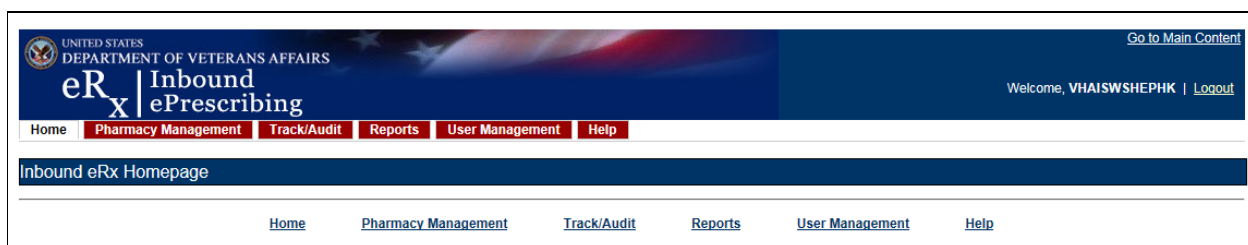

Figure 1-1: Inbound ePrescribing Web-based Application

The IEP Web-based application is discussed in more detail in [Unit 2 - Inbound ePrescribing Web-Based Application](#).

VistA Outpatient Pharmacy eRx Holding Queue

The VistA OP eRx Holding Queue display screens include new VistA screens that are used by VA Pharmacists and Technicians to validate and process eRx's.

The eRx Holding Queue is discussed in more detail in [Unit 3 - VistA Outpatient Pharmacy eRx Holding Queue](#).

Inbound ePrescribing Workflow

The IEP workflow is illustrated in the figure and described below.

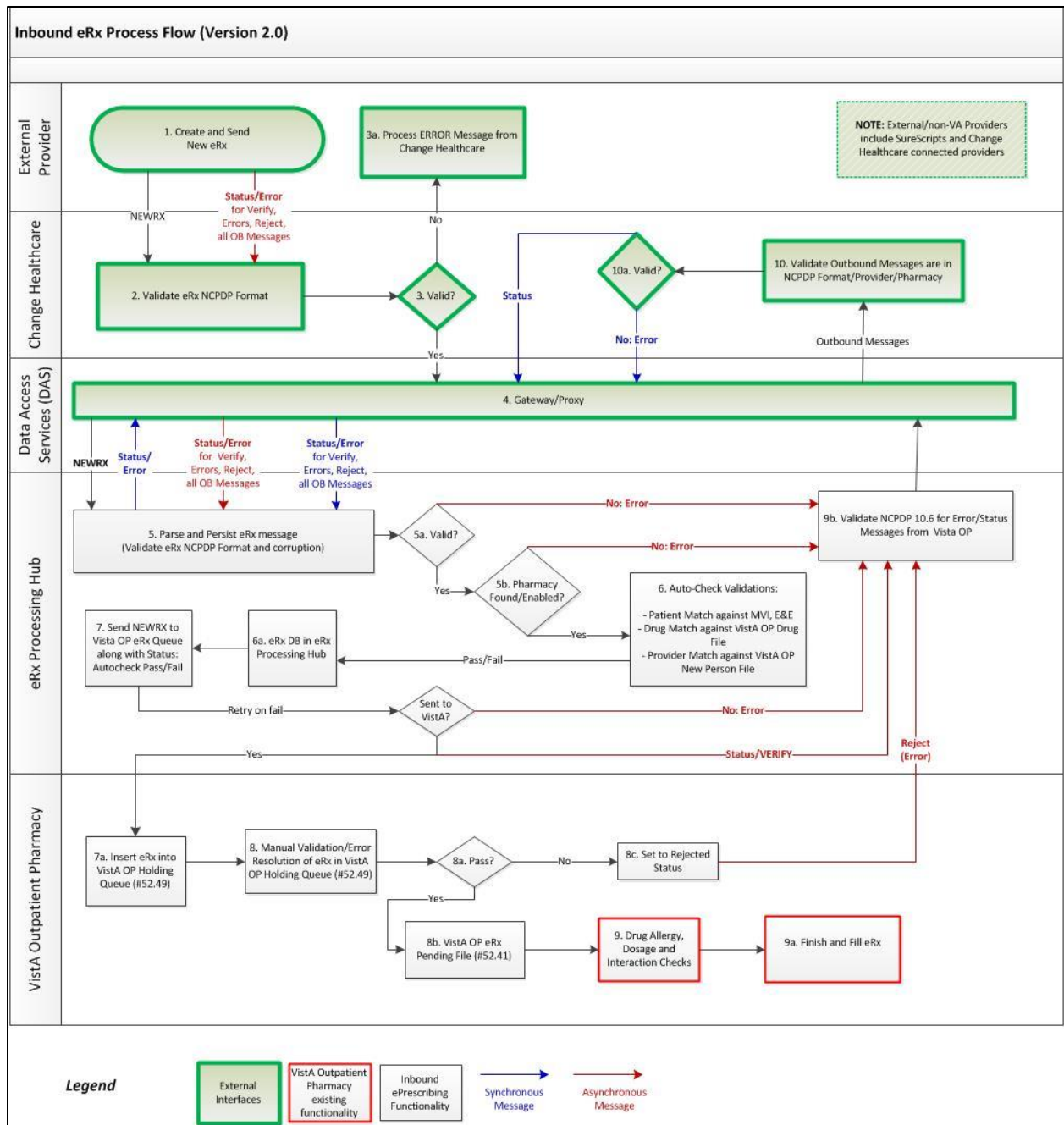

Figure 1-2: Inbound ePrescribing Process Flow

1. eRx_s are sent from an external provider to SureScripts and/or Change Healthcare (CH). CH provides commercial ePrescribing solutions, and for the purposes of the IEP implementation, serves as a gateway to all participating ePrescribing providers nationwide.
2. CH verifies and transmits eRx transactions to/from SureScripts and/or an external provider's EHR system and the IEP system.

3. The eR_xs are routed from CH to the IEP Processing Hub via the Data Access Service (DAS) external gateway. DAS and CH communicate using https requests over a secured network.
4. In the IEP Processing Hub, autochecks occur on the eR_xs for Patient, Provider, and Drug/SIG. The Master Veteran Index (MVI) is used for patient checking, depending on the data set that is sent by the Prescriber for that patient. For patient enrollment and eligibility checks, the Enrollment System (ES) is utilized. The ES assists Veterans to enroll for VA healthcare benefits and is the core application that feeds other VA systems with Enrollment and Eligibility (E&E) data.
5. Patient Registration is also confirmed against the instance of the receiving pharmacy. The Drug Name is matched against the local Drug File first, the VA Product Name next and then next, the National Drug Code (NDC), depending on which it matches first on. As a note, autochecks can be incorrect therefore the data must also be validated against the original eR_x data sent (Please refer to the [Validate Drug/SIG](#) section).
6. The IEP Web-based GUI allows users to view and generate reports on the autocheck results in the Processing Hub, as well as manage VA pharmacy information, and search for and print an eR_x.
7. Once the eR_x has completed all autochecks in the IEP Processing Hub, the original prescription, as well as the outcomes of all of the autochecks (patient, provider, and drug), are transmitted to VistA OP. VistA Link is used for the provider and drug checks against the VistA OP system.
8. The VistA OP's IEP Holding Queue allows for the initial validation and acceptance of an eR_x before being transmitted to Pending Outpatient Orders file for additional order checks and then final dispensing.

Inbound ePrescribing Architecture

The IEP architecture is illustrated in the below figure, which depicts the different programs/applications that IEP interfaces with.

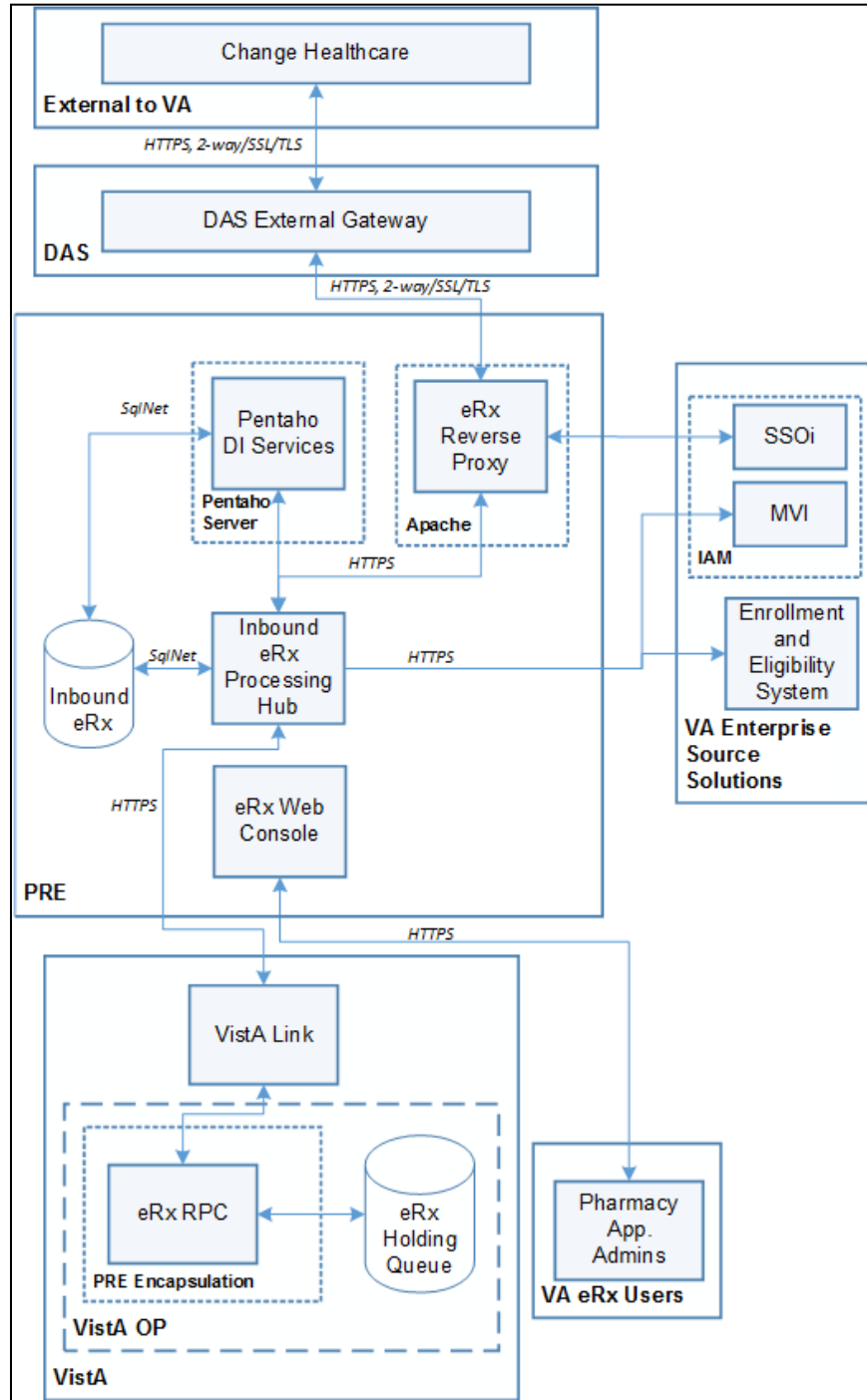

Figure 1-3: Inbound ePrescribing Architecture

Roles and Capabilities

IEP roles and tasks are described in this section as primary and secondary users. Primary users include VA Pharmacists and VA Pharmacy Technicians/Assistants. Secondary users include System Administrators, VA Pharmacy Managers, VA PBM personnel, Non-VA Providers, and External Pharmacy personnel. The following sections provide an overview of primary and secondary user roles and their capabilities within IEP.

VA users have the capability of performing eRx-related tasks in the IEP Web-based application and in the VistA OP eRx Holding Queue module. Specific tasks for each component are described in more detail in [Unit 2 Inbound ePrescribing Web-Based Application](#) and [Unit 3 VistA Outpatient Pharmacy eRx Holding Queue](#).

The primary users of IEP are Pharmacists/Pharmacy Technicians. Secondary user roles of this functionality include:

- Administrator – VA Local and National System Administrators
- Pharmacy Manager – VA Pharmacy Management to include VA management, hospital director, under sec, etc., or anyone outside pharmacy that will need to know how many and what is the cost of the project
- PBM Admin – All VA PBM personnel, including management
- Non-VA Providers – Submit inbound requests to VA and review statuses sent from VA

Details of the roles and capabilities for each user in the IEP Web-based application and the VistA eRx Holding Queue are outlined in the tables below.

Table 1: Inbound ePrescribing Web-Based Application User Roles & Capabilities

User Role	Functionality
Administrator	<ul style="list-style-type: none"> • Full Control, access to all tabs
Pharmacy Management	<ul style="list-style-type: none"> • Home • Pharmacy Management • Track/Audit • Reports • Help
PBM Administrator	<ul style="list-style-type: none"> • Home • Pharmacy Management • Track/Audit • Reports • Help
Pharmacist/Pharmacy Technician	<ul style="list-style-type: none"> • Home • Track/Audit • Reports • Help

User Role	Functionality
Default VA User (Read Only)	<ul style="list-style-type: none">• Home• Reports• Help

Table 2: VistA OP Inbound eRx Holding Queue User Roles & Capabilities

VistA Security Key	PSDRPH	PSO ERX ADV TECH	PSO ERX TECH	PSO ERX VIEW
Validate Patient	X	X	X	
Validate Provider	X	X	X	
Validate Drug/SIG	X	X	X	
Accept Validation	X	X		
Accept eRx	X			
Reject	X	X		
Remove	X	X		
Hold	X	X	X	
Un Hold	X	X	X	
Search/Sort	X	X	X	X
Print	X	X	X	X

Acronyms and Abbreviations

The table below defines the acronyms referenced in this document.

Table 3: Acronyms and Abbreviations

Term	Description
AITC	Austin Information Technology Center
CH	Change Healthcare
CHAMPVA	Civilian Health and Medical Program of the VA
CPRS	Computerized Patient Record System
CSV	Comma-separated value
DAS	Data Access Service
DEA	Drug Enforcement Administration
DME	Durable Medical Equipment
DOB	Date of Birth
DoD	Department of Defense
E&E	Enrollment & Eligibility
EHR	Electronic Health Record
ES	Enrollment System
HIN	Holder Identification Number
ePA	Electronic Prior Authorization
eR _x	ePrescription
FQDN	Fully Qualified Domain Name
IEP	Inbound ePrescribing
MbM	Meds by Mail
MVI	Master Veteran Index
NAIC	North American Industry Classification
NAICS	North American Industry Classification System
NCPDP	National Council for Prescription Drug Programs
NDC	National Drug Code
NPI	National Provider Identifier
NSD	National Service Desk
OI&T	Office of Information & Technology
OP	Outpatient Pharmacy
PBM	Pharmacy Benefits Management

Term	Description
PCS	Patient Care Services
PIN	Personal Identification Number
POC	Point of Contact
PPO	Program Planning Oversight
PRE	Pharmacy Reengineering
PHI	Protected Health Information
PHR	Personal Health Record
PII	Personally Identifiable Information
PIV	Personal Identification Verification
PRE	Pharmacy Reengineering
SSN	Social Security Number
Tech	Technician
UI	User Interface
UPN	Universal Product Number
UPC	Universal Product Code
VA	Department of Veterans Affairs
VAMC	VA Medical Center
VDL	VA Documentation Library
VHA	Veterans Health Administration
VISN	Veterans Integrated Service Network
VistA	Veterans Health Information Systems and Technology Architecture

Unit 2. Inbound ePrescribing Web-Based Application

Inbound ePrescribing Web-Based Application Overview

Purpose

The Inbound ePrescribing (IEP) Web-based application provides eRx management, administration, and monitoring capabilities.

Access Requests

Please contact the supervisor or the administrator assigned at your local site for managing the application for questions on access to the IEP Web-based application and/or modifications to user roles/permissions.

Accessing the Application

A Personal Identification Verification (PIV) card is required to access the application, using the following steps:

1. On the VA Single Sign-on screen, select the **Sign In with VA PIV Card** icon.



Figure 2-1: VA Single Sign-on

2. In the “Select a Certificate” dialog, select the desired certificate and then select **OK**.

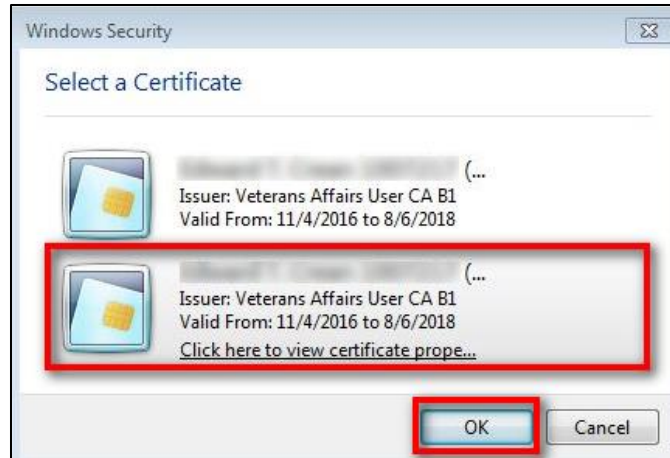

Figure 2-2: Select a Certificate

3. In the “ActivClient Login” dialog, enter the Personal Identification Number (PIN) in the “PIN” text box and select **OK**.

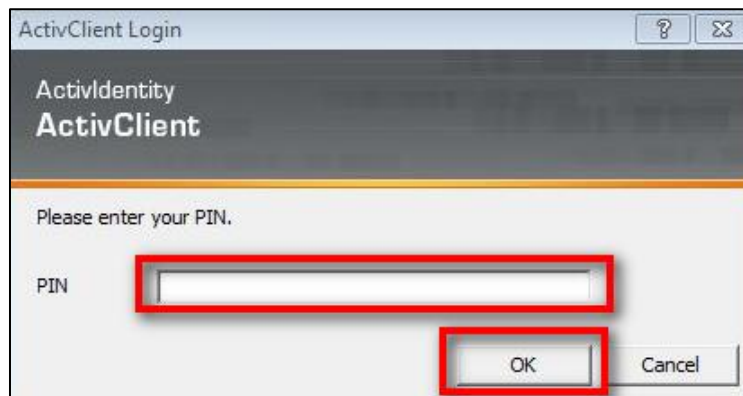

Figure 2-3: Active Client Login

4. A warning message displays. Select Accept.

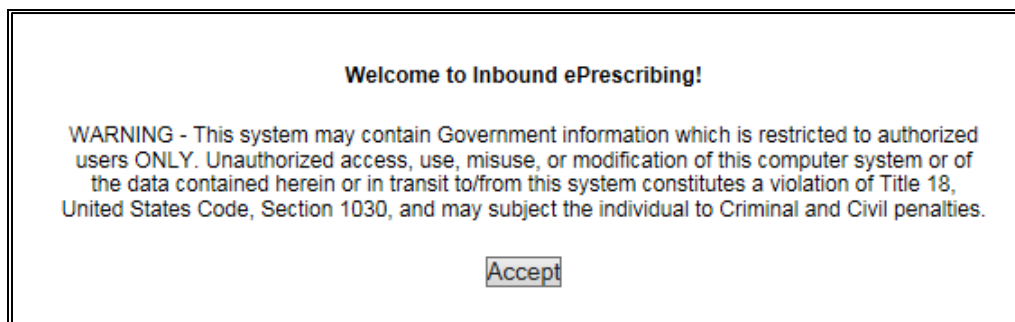

Figure 2-4: Warning Message

When authentication and authorization is successful, the application home screen displays.



Figure 2-5: Home Screen

Screen Navigation and Description

The following figure outlines the key areas of the screen layout. Brief descriptions of the screen layout are provided below:

1. The logged-in user's VA User ID and logout link displays on the right side of the banner.
2. Below the banner, the main tabs display for accessing the screens within the application.
3. The name of the screen displays below the main tabs.
4. The bottom of the screen also contains links to the main tabs.
5. On the top-right of the screen is a **Go to Main Content** link for Section 508 purposes to allow a user to be directed to the main content on the screen.

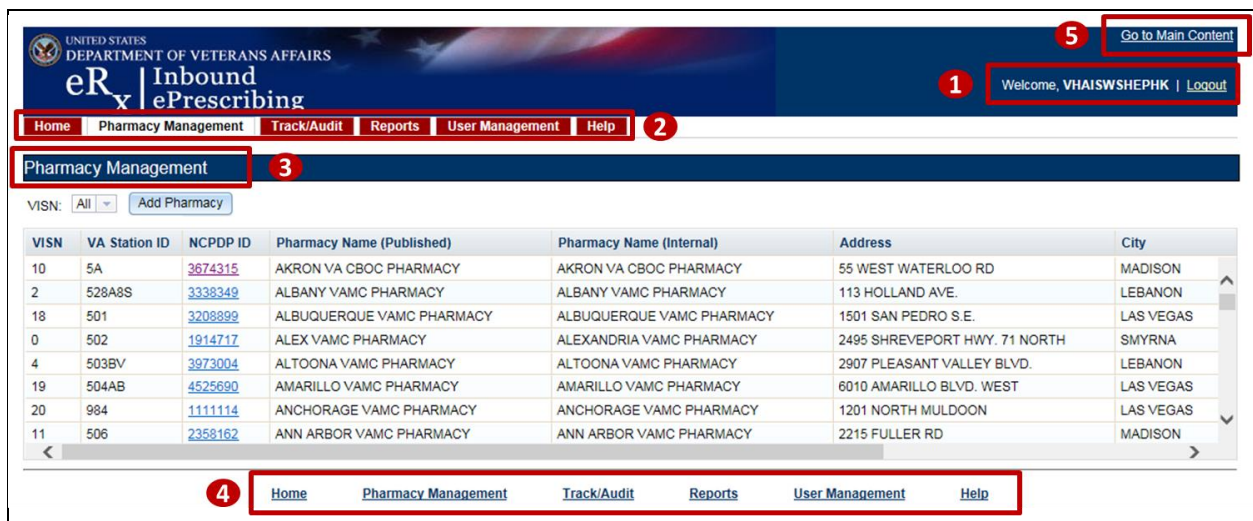

Figure 2-6: Web-Based Application Screen Layout

Only the menu bar tabs that the user has access to display. Access to the tab displays or screens is granted or restricted by roles assigned to the user by the administrator; refer to the [Roles and Capabilities](#) section. There are links to the tabs on the bottom of each page as well. The tabs are:

- **Home/Inbound eRx Homepage** – All Users
- **Pharmacy Management** – Administrators, Pharmacy Managers, and PBM Admin

- **Track/Audit** – Administrators, Pharmacy Managers, PBM Admin, and Pharmacists/Pharmacy Technicians
- **Reports** – All Users
- **User Management** – Administrators
- **Help** – All Users

Inbound eRx Homepage

The Inbound eRx Homepage is displayed when successful login authentication and verification is completed. The Inbound eRx Homepage is always accessible by selecting the **Home** tab in the menu bar. The Home screen is accessible to all user roles. However, only the tabs authorized for the user’s role are displayed.

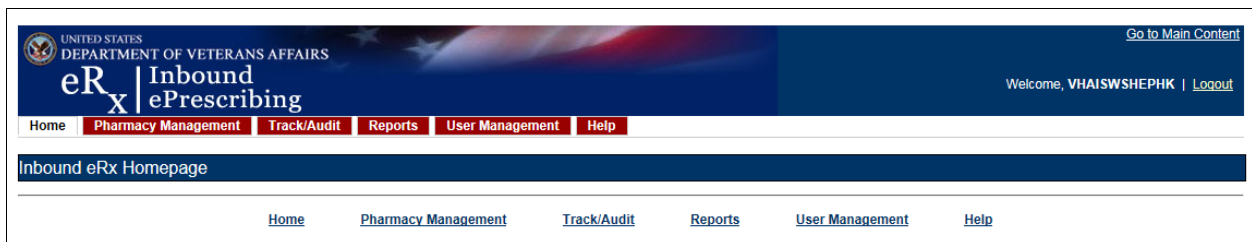

Figure 2-7: Home Screen

Pharmacy Management

To access the Pharmacy Management screen, select the **Pharmacy Management** tab in the menu bar. The Pharmacy Management screen displays the Pharmacy Management table that provides information about pharmacies and allows Administrators and Pharmacy Managers to search for, add, and edit pharmacies. Users can also enable/disable receiving prescriptions targeted for a particular pharmacy Inbound eRx delivery. The default view displays all VA pharmacies. Refer to the [Pharmacy Management](#) section of this manual for more information.

UNITED STATES DEPARTMENT OF VETERANS AFFAIRS
eRx Inbound ePrescribing
 Home **Pharmacy Management** Track/Audit Reports User Management Help

Pharmacy Management

VISN: All Add Pharmacy

VISN	VA Station ID	NCPDP ID	Pharmacy Name (Published)	Pharmacy Name (Internal)	Address	City
10	5A	3674315	AKRON VA CBOC PHARMACY	AKRON VA CBOC PHARMACY	55 WEST WATERLOO RD	MADISON
2	528A8S	3338349	ALBANY VAMC PHARMACY	ALBANY VAMC PHARMACY	113 HOLLAND AVE.	LEBANON
18	501	3208899	ALBUQUERQUE VAMC PHARMACY	ALBUQUERQUE VAMC PHARMACY	1501 SAN PEDRO S.E.	LAS VEGAS
0	502	1914717	ALEX VAMC PHARMACY	ALEXANDRIA VAMC PHARMACY	2495 SHREVEPORT HWY. 71 NORTH	SMYRNA
4	503BV	3973004	ALTOONA VAMC PHARMACY	ALTOONA VAMC PHARMACY	2907 PLEASANT VALLEY BLVD.	LEBANON
19	504AB	4525690	AMARILLO VAMC PHARMACY	AMARILLO VAMC PHARMACY	6010 AMARILLO BLVD. WEST	LAS VEGAS
20	984	1111114	ANCHORAGE VAMC PHARMACY	ANCHORAGE VAMC PHARMACY	1201 NORTH MULDOON	LAS VEGAS
11	506	2358162	ANN ARBOR VAMC PHARMACY	ANN ARBOR VAMC PHARMACY	2215 FULLER RD	MADISON

Figure 2-8: Pharmacy Management Screen

Track/Audit

To access the Track/Audit eRx screen, select the **Track/Audit** tab in the menu bar. The Track/Audit eRx screen displays allow users to track and view an audit trail of eRx's.

Figure 2-9: Track/Audit Screen

Reports

To access the Reports screen, select the **Reports** tab in the menu bar. The Reports screen provides all users with the ability to run and view a Summary Report.

The system uses the comma-separated value (.CSV) format. Users can view reports using a third-party tool, such as Microsoft Excel.

VISN	VA Station ID	NCPDP ID	Pharmacy Name	Address	#New Rx	#Pharmacy Disabled	#Rejected at Hub	#Passed Autocheck	#Failed Autocheck	#Rejected by Pharmacist	#Rx Filled	#Rx In Process
2	984	1111114	ANCHORAGE VAMC PHARMACY	111 LAS VEGAS, NV 89193-7895	12	0	1	1	10	2	0	9
7	984	1111119	ATLANTA VAMC PHARMACY	1670 CLAIRMONT ROAD ASHEVILLE, NC 28815	2	0	2	0	0	0	0	0
4	529	3964295	BUTLER VAMC PHARMACY	325 NEWCASTLE ROAD LEBANON, PA 17042-3005	2	2	0	0	4	0	0	0
1	UNKNW	0	UNKNOWN	UNKNOWN UNKNOWN, ZZ 99999-999	2	0	0	0	2	0	0	0
Totals >>					18	2	3	1	16	2	0	9

Report as of: Wed Nov 8 2017 12:37
Number of Records: 4

Figure 2-10: Reports Screen

User Management

To access the User Management screen, select the **User Management** tab in the menu bar. The User Management screen provides Administrators with the ability to add and delete users and modify user roles. This screen only displays for users with Administrator access.

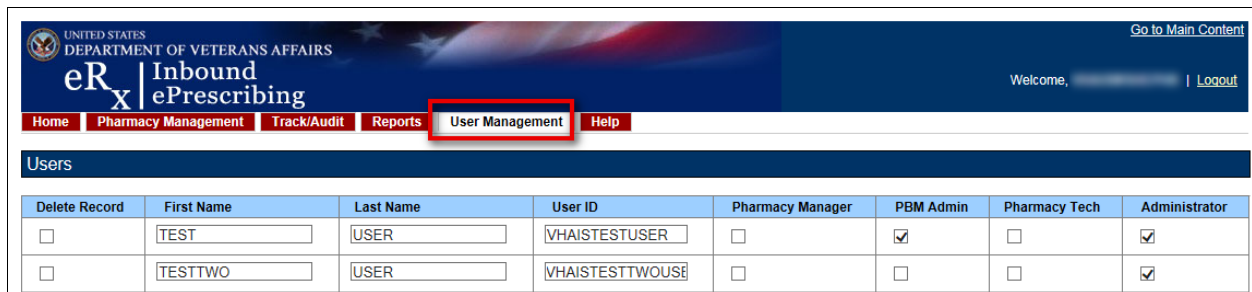

Delete Record	First Name	Last Name	User ID	Pharmacy Manager	PBM Admin	Pharmacy Tech	Administrator
<input type="checkbox"/>	TEST	USER	VHAISTESTUSER	<input type="checkbox"/>	<input checked="" type="checkbox"/>	<input type="checkbox"/>	<input checked="" type="checkbox"/>
<input type="checkbox"/>	TESTTWO	USER	VHAISTESTTWOUSER	<input type="checkbox"/>	<input type="checkbox"/>	<input type="checkbox"/>	<input checked="" type="checkbox"/>

Figure 2-11: User Management Screen

Help Page

To access the Help page, select the **Help** tab in the menu bar. The Help page provides help topics and production support information.



Figure 2-12: Help Screen

When the **Help** tab is selected, the Help Page displays in a new window.

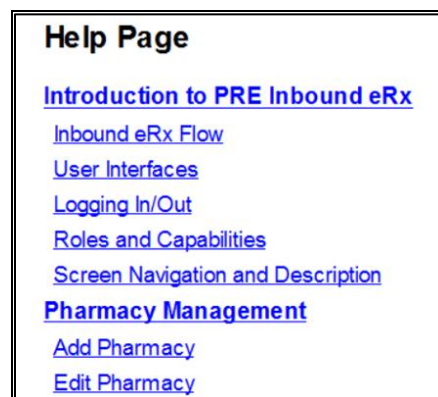

Figure 2-13: Help Page

Inbound ePrescribing Web-based Application Capabilities

The following sections provide descriptions of the IEP Web-based application’s capabilities within each tab.

Pharmacy Management

The Pharmacy Management screen displays the Pharmacy Management table. The default view displays all VA pharmacies. Actions available to users include:

- [Searching for a Pharmacy](#)
- [Adding a Pharmacy](#)
- [Updating a Pharmacy](#)

Searching for a Pharmacy

Users can search for a pharmacy from the Pharmacy Management screen. The default view lists all VA pharmacies.

To search for a pharmacy:

1. Select the desired VISN number from the “VISN” drop down.
2. The Pharmacy Management table for the selected VISN displays.



Figure 2-14: Narrow Search by VISN

Adding a Pharmacy

To add a new pharmacy, please submit a help desk ticket to the VA National Service Desk (NSD) at 855-NSD-HELP (673-4357) and reference “Inbound eRx”.

NOTE: The pharmacy must be pre-registered as a pharmacy in ePharmacy. ePharmacy is supported by CH therefore ePharmacy registration adds the pharmacy to the same CH Pharmacy Directory (*NCPDP ID is required) utilized by Inbound eRx. For IEP, CH must also enable eRx support for the pharmacy in their Directory. Also, the pharmacy must be “registered” with IEP by adding the pharmacy through the IEP Web-based application.

Updating a Pharmacy

To update information for a VA pharmacy, please submit a help desk ticket to the VA National Service Desk (NSD) at 855-NSD-HELP (673-4357) and reference “Inbound eRx”.

Disable eR_x

To completely halt a specific Pharmacy from receiving ePrescriptions, please submit a help desk ticket to the VA National Service Desk (NSD) at 855-NSD-HELP (673-4357) and reference “Inbound eR_x”.

NOTE: If a pharmacy is to be disabled for a long duration, a request must be made to CH. Note that the NSD will route the ticket to an IEP administrator to assist with this step. CH can switch the pharmacy to fax only or turn off eR_x delivery (electronic or fax) completely.

Temporarily Disable eR_x

In case where a site needs to halt receiving ePrescriptions temporarily, use Disable eR_x/Enable eR_x fields.

Disabling a pharmacy allows users the ability to temporarily disable the pharmacy from receiving eR_xs in the event of a natural or facility disaster, maintenance, or move. This disables the pharmacy from receiving New eR_xs, but outbound messages still go back to the external provider via CH. The pharmacy is disabled on the Processing Hub but no changes are made in CH.

NOTE: The enable/disable in the Processing Hub is for a temporary disable, which will also allow outgoing messages (rejection messages for any new eR_xs still in process) to continue flowing from VistA. Additionally, incoming messages will still flow from CH to the Processing Hub for the pharmacy, however an error message will be returned to the provider saying that Inbound eR_x messaging is currently not available. In these cases, CH will then send a fax of the eR_x to the pharmacy.

To temporarily disable a pharmacy:

1. From the Pharmacy Management screen, select the hyperlink for the desired pharmacy to edit in the “NCPDP ID” column.

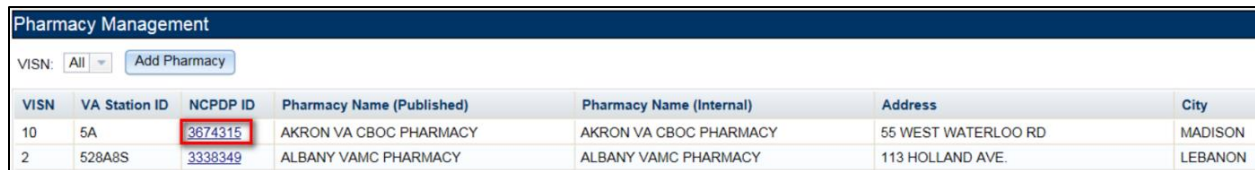

VISN	VA Station ID	NCPDP ID	Pharmacy Name (Published)	Pharmacy Name (Internal)	Address	City
10	5A	3674315	AKRON VA CBOC PHARMACY	AKRON VA CBOC PHARMACY	55 WEST WATERLOO RD	MADISON
2	528A8S	3338349	ALBANY VAMC PHARMACY	ALBANY VAMC PHARMACY	113 HOLLAND AVE.	LEBANON

Figure 2-15: NCPDP ID Column Hyperlinks

The Edit Pharmacy screen displays.

The screenshot shows the 'Edit Pharmacy' form with the following fields and values:

Field	Value
Pharmacy Name (Published): (Required)	ALBANY VAMC PHARMACY
Inbound Erx Enabled:	No
VISN: (Required)	2
VA Station ID (Required) :	528A8
Pharmacy Name (Internal): (Required)	ALBANY VAMC PHARMACY
Pharmacy Address Line 1: (Required)	113 HOLLAND AVE.
Pharmacy Address Line 2:	
Pharmacy City: (Required)	LEBANON
Pharmacy State: (Required)	Pennsylvania

Figure 2-16: Edit Pharmacy Screen

2. Select **No** from the “Inbound Erx Enabled” drop down.

This screenshot is identical to Figure 2-16, but the 'Inbound Erx Enabled' drop-down menu is highlighted with a red rectangular box to indicate the selection step.

Figure 2-17: eRx Enabled Drop Down

3. At the bottom of the Edit Pharmacy screen, select **Update** to save all changes. The date that the fields were modified displays in the “Updated Date” field.

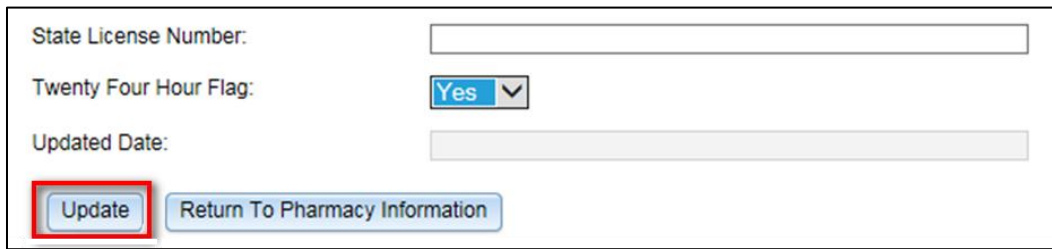

Figure 2-18: Update Pharmacy Information

4. Selecting the **Return to Pharmacy Information** button returns the user to the Pharmacy Management screen.

Enable eRx

The pharmacy can be enabled once it is ready to receive eRxS again. To enable a pharmacy select **Yes** from the “Inbound Erx Enabled” drop down on the Edit Pharmacy screen.

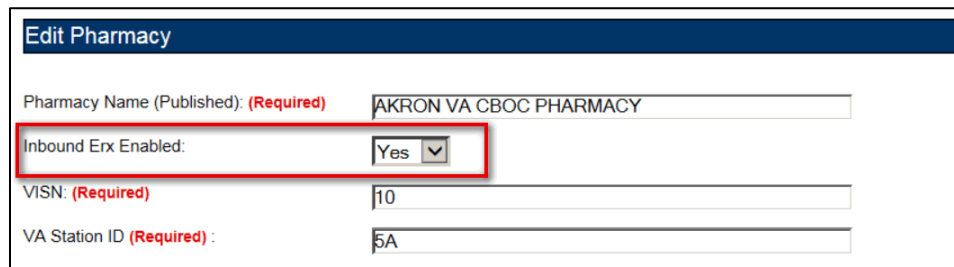

Figure 2-19: Enable/Disable Pharmacy

NOTE: If a pharmacy is not enabled and a prescription comes in for that pharmacy, an error message is sent back to the provider’s EHR system to notify the provider that the pharmacy is not currently receiving eRxS.

Track/Audit

The Track/Audit screen allows users to search and track prescriptions and provides the ability to view and print the details of a prescription.

Searching for and Tracking/Auditing a Prescription

To search for a prescription:

1. Select the desired search criteria from the drop downs and enter search keywords in the text fields.

Figure 2-20: Track/Audit Search Criteria

Table 4: Track/Audit Search Criteria Descriptions

Search Field	Field Type	Description	Drop Down Options
VISN	Drop Down	VISN number that a VA pharmacy is associated with	All VISNs, each VISN number
Station ID	Text	Station ID of the VA pharmacy	N/A
From	Text or Calendar Drop Down	Beginning date. Choose the From date for the date range search, select date from calendar or type date	N/A
To	Text or Calendar Drop Down	End date. Choose the To date for a date range search; select the date from the calendar or enter a date in MM/DD/YYYY format	N/A
Message Type	Drop Down	Type of the NCPDP message type	All, NewRx, Status, Error, Verify
Message ID	Text	Prescription message ID (generated by Change Healthcare for incoming eRx's)	N/A
Relates to Message ID	Text	To search for messages related to a Message ID	N/A
Patient SSN	Text	Patient Social Security Number	N/A
Patient Last Name	Text	Patient last name	N/A
Patient First Name	Text	Patient first name	N/A
Patient DOB	Drop Down	Patient date of birth	Calendar
Prescriber NPI	Text	Prescriber National Provider Identifier (NPI)	N/A
Prescribed Drug	Text	Drug prescribed from the eRx	N/A
Prescriber First Name	Text	First name of prescriber	N/A
Prescriber Last Name	Text	Last name of prescriber	N/A
Message Status	Drop Down	Processing Hub message status	Autocheck Processing Completed, VistA OP Delivery Successful, VistA OP Delivery

Search Field	Field Type	Description	Drop Down Options
			Retries Exceeded, Autocheck in Progress, Pharmacy Inbound eRx Not Enabled, Pharmacy Unknown
eRx Reference #	Text	Unique, internal VA reference # assigned to all messages	N/A
Sent or Received	Drop Down	Select Sent (Outbound) or Received (Inbound) messages	Received, Sent

2. Select **Search** to execute the search.

Figure 2-21: Track/Audit eRx Search

The search results display in the table. The total number of records in the search results display at the bottom of the table.

eRx Reference #	Message Id	Message Type	Prescriber Name	Prescriber NPI	VISN	Station ID	Pharmacy Name	Address	Patient Name	Patient DOB	Patient SSN	Drug Prescribed
1962	6305867916 48299458	NewRx	TEST PRESCRIBER, ERX		2	984	TEST PHARMACY	12345 MAIN STREET FORT WORTH, TX 76102	PATIENT, TEST			RISEROL E NA 35M TAB
1960	6305867911 95314821	NewRx	TEST PRESCRIBER, ERX		2	984	TEST PHARMACY	12345 MAIN STREET FORT WORTH, TX 76102	PATIENT, TEST			MELPHAL 2MG TAB
1958	6305867879 27951797	NewRx	TEST PRESCRIBER, ERX		2	984	TEST PHARMACY	12345 MAIN STREET FORT WORTH, TX 76102	PATIENT, TEST			TEST DRUG

Figure 2-22: Search Results

The Search Results fields and descriptions are listed in the table below.

Table 5: Search Results Fields & Descriptions

Field	Description
eRx Reference #	Unique, internal VA reference # assigned to all messages
Message Id	Message identification number

Field	Description
Message Type	The type of message. Message types include: New eRx, Error, Verify, and Status.
Prescriber Name	First and last name of the prescriber
Prescriber NPI	National Provider Identifier for the prescriber
VISN	VISN that the VA pharmacy is associated with
Station ID	Station ID of the VA pharmacy
Pharmacy Name	Internal VA pharmacy name
Address	Address of VA pharmacy
Patient Name	First and last name of the patient
Patient DOB	Date of birth for the patient
Patient SSN	Social security number of the patient
Drug Prescribed	Drug prescribed to the patient
Relates to Message ID	Lists messages related to a particular Message ID
Received Date	Date that the eRx was received by VA
Patient AutoCheck Status	Results of system patient auto-validation check
Provider AutoCheck Status	Results of system provider auto-validation check
Drug AutoCheck Status	Results of system drug auto-validation check
Message Status	Current status of the message

Export Search Results

From the Track/Audit tab, users have the capability of exporting the search results. Exports are in .CSV format and can be viewed in Microsoft Excel.

To export the search results:

1. Select the **Export** button.



eRx Reference #	Message Id	Message Type	Prescriber Name	Prescriber NPI	VISN	Station ID	Pharmacy Name	Address	Patient Name
2400	smoketestrail2901sm	NewRx	TEST PRESCRIBER, ERX	1063868685	18	983	CHYSHR	21930 SE 51st St, JoseyIn Westchester, IN 98029	INBERXRPTE STPATS, STEVEN
2391	smoketestrail2806sm	NewRx	TEST PRESCRIBER, ERX	1063868685	18	983	CHYSHR	21930 SE 51st St, JoseyIn Westchester, IN 98029	INBERXRPTE STPATS, STEVEN
2389	smoketestrail2805sm	NewRx	TEST PRESCRIBER, ERX	1063868685	18	983	CHYSHR	21930 SE 51st St, JoseyIn Westchester, IN 98029	INBERXRPTE STPATS, STEVEN

Figure 2-23: Export Search Results

A prompt displays asking to Open or Save the results.

2. Select Open to view the results.
3. To save the results, select Save. The system displays a Save As dialog. Navigate to a location on your system to save the file.

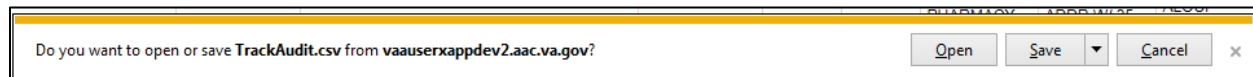
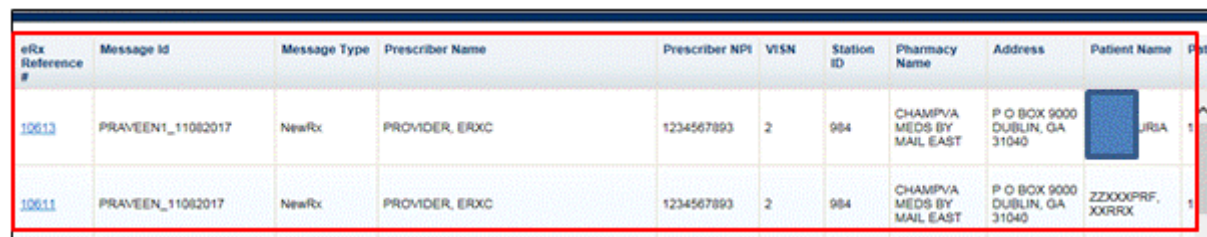

Figure 2-24: Track/Audit Export Prompt (after clicking Export Buttons)

Inbound/Outbound Message Detail

Inbound/outbound message detail information is reviewed and managed under the Track/Audit tab.

To access the detail screen of a message, select the hyperlink in the “eRx Reference #” column.



eRx Reference #	Message Id	Message Type	Prescriber Name	Prescriber NPI	VISN	Station ID	Pharmacy Name	Address	Patient Name
10013	PRAVEEN_11082017	NewRx	PROVIDER, ERXC	1234567893	2	984	CHAMPVA MEDS BY MAIL EAST	P O BOX 9000 DUBLIN, GA 31040	JIRA
10011	PRAVEEN_11082017	NewRx	PROVIDER, ERXC	1234567893	2	984	CHAMPVA MEDS BY MAIL EAST	P O BOX 9000 DUBLIN, GA 31040	ZZXXXPRF, XXRRX

Figure 2-25: Track/Audit Grid View

NewRx Message

The NewRx detail screen displays the new eRx from an external provider.

To access the New Rx detail screen, select the hyperlink in the “eRx Reference #” column.

eRx Reference #	Message ID	Message Type	Prescriber Name	Prescriber NPI	VISN	Station ID	Pharmacy Name	Address	Patient Name	Pati
10611	PRAVEEN_11082017	NewRx	PROVIDER, ERXC	1234567893	2	984	CHAMPVA MEDS BY MAIL EAST	P O BOX 9000 DUBLIN, GA 31040	[REDACTED]	1
10611	PRAVEEN_11082017	NewRx	PROVIDER, ERXC	1234567893	2	984	CHAMPVA MEDS BY MAIL EAST	P O BOX 9000 DUBLIN, GA 31040	ZZXXXPRF, XXRRX	1

Figure 2-26: eRx Reference # Hyperlink

The details of the NewRx message display, including the following sections:

- Pharmacy
- Prescriber
- Patient
- Prescription

The eRx Reference # is located in the Prescription section of the screen, as illustrated in the figure below.

Return to Search
Print

NewRx Status: VISTAOP_DELIVERY_SUCCESSFUL Received Date: 11/08/2017

PHARMACY

Name: CHAMPVA MEDS BY MAIL EAST NCPDP ID: 1111114
 Address: P O BOX 9000
 DUBLIN, GA 31040
 Phone: (866) 229-7389

PRESCRIBER

First: ERXC
 Mid:
 Last: PROVIDER
 Address: 999 SAD AVE
 FRISCO, TX 75034
 NPI: 1234567893 DEA: AB1234563
 Phone: (817) 887-0000 State Lic:
 Agent:

PATIENT

First: XXRRX
 Mid:
 Last: ZZXXXPRF
 Address: STREET
 TEMPE, AZ 33647
 DOB: [REDACTED] Gender: U

PRESCRIPTION

Drug Prescribed: METHYLPREDNISOLONE ACETATE 40MG/ML INJ Days Supply: 1
 Quantity: 1 Date Written: 11/08/2017
 Potency Unit Cd: Tablet Dosing Unit
 Drug Form:
 Drug Strength:
 Refills: 0
 SIG: SHAKE WELL AND INJECT 1 ML (40MG) IM INTO MUSCLE IN CLINIC
 eRx Ref Num: 10611
 Message ID: PRAVEEN_11082017
 Ref to Msg ID:
 Dispense Notes: 0 = No Product Selection Indicated
 Comments:
 Plan ID: RxGRP:
 RxBIN#: RxPCN:

Figure 2-27: Track/Audit Detail Screen for NewRx Message Type

To return to the search results screen, select the **Return to Search** button. To print the eRx details, select the **Print** button.

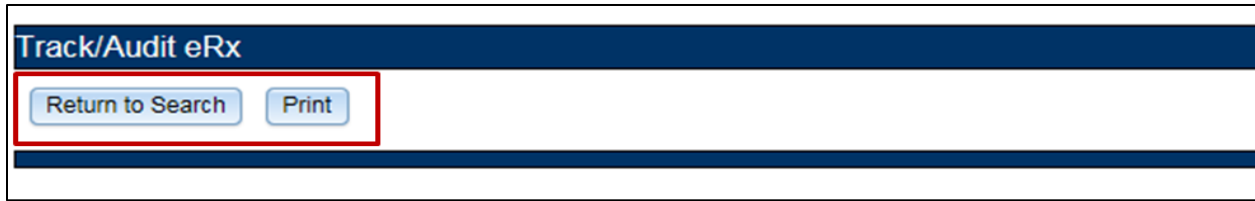

Figure 2-28: NewRx Detail Screen: Available Actions

Error Messages

Error messages can be either generated by the Processing Hub or generated by VistA. Examples of Processing Hub errors include, but are not limited to, Pharmacy not found, Pharmacy not enabled, NCPDP corrupted, and VistA transmission failed. Errors from VistA include the Reject messages sent back when a user rejects an eRx in the Holding Queue.

To access the Error message detail screen, select the hyperlink in the “eRx Reference #” column. The Error message detail screen displays the error message details sent and received by the Processing Hub.

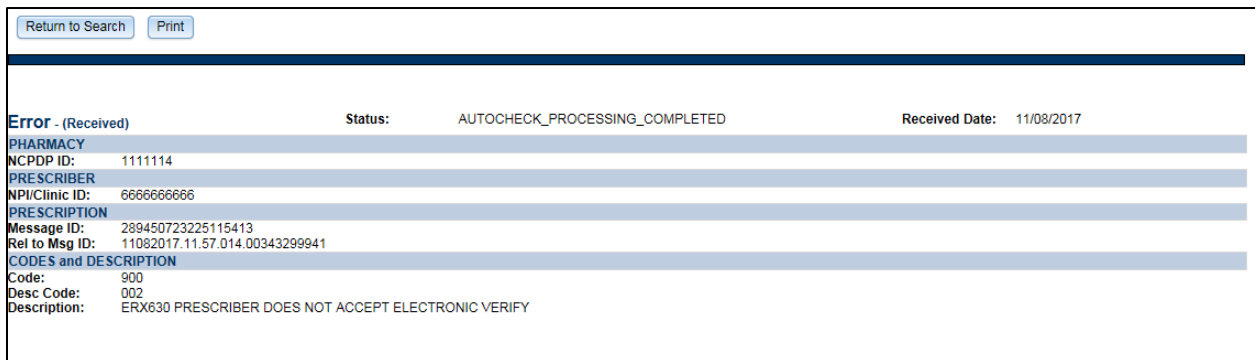

Figure 2-29: Track/Audit Detail Screen for Error Message Type

The details of the Error message include the following sections:

- Pharmacy: Includes the NCPDP ID of the pharmacy
- Prescriber: Includes the NPI number of the prescriber
- Prescription: Includes the Message ID and Relates to Message ID
- Codes and Description: Includes the Code, Description Code, and Description in the message. Refer to [Appendix B. NCPDP Error Codes](#).

To return to the search results screen, select the **Return to Search** button. To print the Error message details, select the **Print** button.

Return to Search		Print	
NewRx	Status:	VISTAOP_DELIVERY_SUCCESSFUL	Received Date: 11/08/2017
PHARMACY			
Name:	CHAMPVA MEDS BY MAIL EAST	NCPDP ID:	1111114
Address:	P O BOX 9000 DUBLIN, GA 31040		
Phone:	(866) 229-7389		
PRESCRIBER			
First:	ERXC		
Mid:			
Last:	PROVIDER		
Address:	999 SAD AVE FRISCO, TX 75034		
NPI:	1234567893	DEA:	AB1234563
Phone:	(817) 887-0000	FAX:	
Agent:			State Lic:
PATIENT			

Figure 2-30: Track/Audit Detail Screen - Return to Search/Print Buttons

Verify Messages

Verify messages are sent when the transmission of an eRx from the Processing Hub to VistA is successful.

To access the Verify message detail screen, select the hyperlink in the “eRx Reference #” column.

The Verify message detail screen displays the verify message details sent by the Processing Hub.

NOTE: To search for Verify messages, select “Sent” from the **Sent or Received** drop-down menu.

VISN:	All	VA Station ID:		From:	11/8/2017	To:	11/8/2017
Message Type:	All	Message ID:		Relates to Message ID:			
Patient SSN:		Patient Last Name:		Patient First Name:			
Patient DOB:		Prescriber NPI:		Prescribed Drug:			
Prescriber Last Name:		Prescriber First Name:		Message Status:	All		
eRx Reference #:				Sent or Received:	Received		
<input type="button" value="Search"/> <input type="button" value="Clear"/> <input type="button" value="Export"/>							

Figure 2-31: Track/Audit Screen Criteria - Sent or Received Dropdown

Verify - (Sent)	Status:	OB_MSG_SEND_COMPLETED	Received Date:	11/08/2017
PHARMACY				
NCPDP ID:	1111114			
PRESCRIBER				
NPI/Clinic ID:	6666666666			
PRESCRIPTION				
Message ID:	11082017.11.57.014.00343299941			
Rel to Msg ID:	PRAVEEN1_11082017			
CODES and DESCRIPTION				
Code:	010			
Desc Code:				
Description:				

Figure 2-32: Track/Audit Detail Screen Status/Verify Message Type

The details of the Verify message include the following sections:

- Pharmacy: Includes the NCPDP ID of the pharmacy
- Prescriber: Includes the NPI number of the prescriber
- Prescription: Includes the Message ID and Relates to Message ID

- Codes and Description: Includes the Code, Description Code, and Description in the message. Refer to [Appendix B. NCPDP Error Codes](#).

To return to the search results screen, select the **Return to Search** button. To print the Verify message details, select the **Print** button.

Status Messages

A Status message is received when an outbound message from the Processing Hub or VistA reaches CH and/or the external provider successfully.

To access the Status message detail screen, select the hyperlink in the “eR_x Reference #” column.

The Status message detail screen displays the status message details received by the Processing Hub.

NOTE: To search for Status messages, select “Received” from the **Sent or Received** drop-down menu.

Error - (Received)	Status: AUTOCHECK_PROCESSING_COMPLETED	Received Date: 11/09/2017
PHARMACY		
NCPDP ID:	1111114	
PRESCRIBER		
NPI/Clinic ID:	666666666	
PRESCRIPTION		
Message ID:	289450723225115413	
Rel to Msg ID:	11082017.11.57.014.00343299941	
CODES and DESCRIPTION		
Code:	900	
Desc Code:	002	
Description:	ERX630 PRESCRIBER DOES NOT ACCEPT ELECTRONIC VERIFY	

Figure 2-33: Track/Audit Detail Screen Status Message Type

The details of the Status message include the following sections:

- Pharmacy: Includes the NCPDP ID of the pharmacy
- Prescriber: Includes the NPI number of the prescriber
- Prescription: Includes the Message ID and Relates to Message ID
- Codes and Description: Includes the Code, Description Code, and Description in the message, where applicable. Refer to [Appendix B. NCPDP Error Codes](#).

To return to the search results screen, select the **Return to Search** button. To print the Status message details, select the **Print** button.

Reports

The Reports tab is used to generate high-level reports on total number of eR_xs, grouped by various statuses/errors within a VISN or within a pharmacy. From the Reports tab, users can generate, view, and export a Summary Report.

Summary Report

The Summary Report provides a summary of eR_x auto-validation checks. To run a Summary Report:

1. From the Reports screen, select **Summary Report** from the “Select Report” drop down.

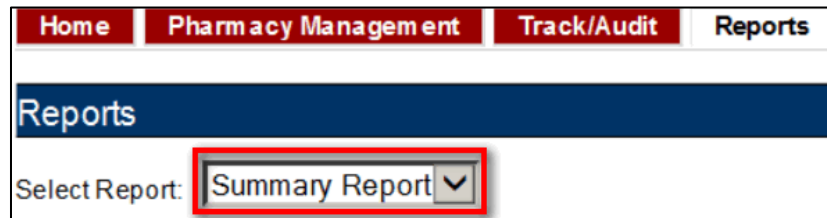

Figure 2-34: Summary Report Dropdown

2. Select the desired VISN from the “VISN” drop down. The drop down contains each VISN number as well as an **ALL** selection to select all VISNs.

A screenshot of the 'Reports' screen in the eRx Inbound ePrescribing system. The page header includes the VA logo and 'eRx Inbound ePrescribing' text. A navigation bar contains tabs for 'Home', 'Pharmacy Management', 'Track/Audit', 'Reports', 'User Management', and 'Help'. The 'Reports' section shows a 'Select Report:' dropdown set to 'Summary Report'. Below this are filter criteria: 'VISN:' with a dropdown menu (highlighted with a red box), 'Station ID:' with a dropdown set to 'All', 'From:' with a date '11/1/2017', and 'To:' with a date '11/8/2017'. There are 'Run Report' and 'Export' buttons. A table displays report data with columns for VISN, NCPDP ID, Pharmacy Name, Address, #New Rx, #Pharmacy Disabled, #Rejected at Hub, #Passed Autocheck, #Failed Autocheck, #Rejected by Pharmacist, #Rx Filled, and #Rx In Process. A 'Totals >>' row is at the bottom of the table. The footer contains the same navigation tabs as the top.

Figure 2-35: Reports Screen Filter Criteria – Select VISN from Dropdown

3. To narrow the search by VA Station ID, select the Station ID for the report.

UNITED STATES DEPARTMENT OF VETERANS AFFAIRS
eRx Inbound ePrescribing
 Home Pharmacy Management Track/Audit Reports User Management Help

Go to Main Content
 Welcome, VHAISPCHALLP | Logout

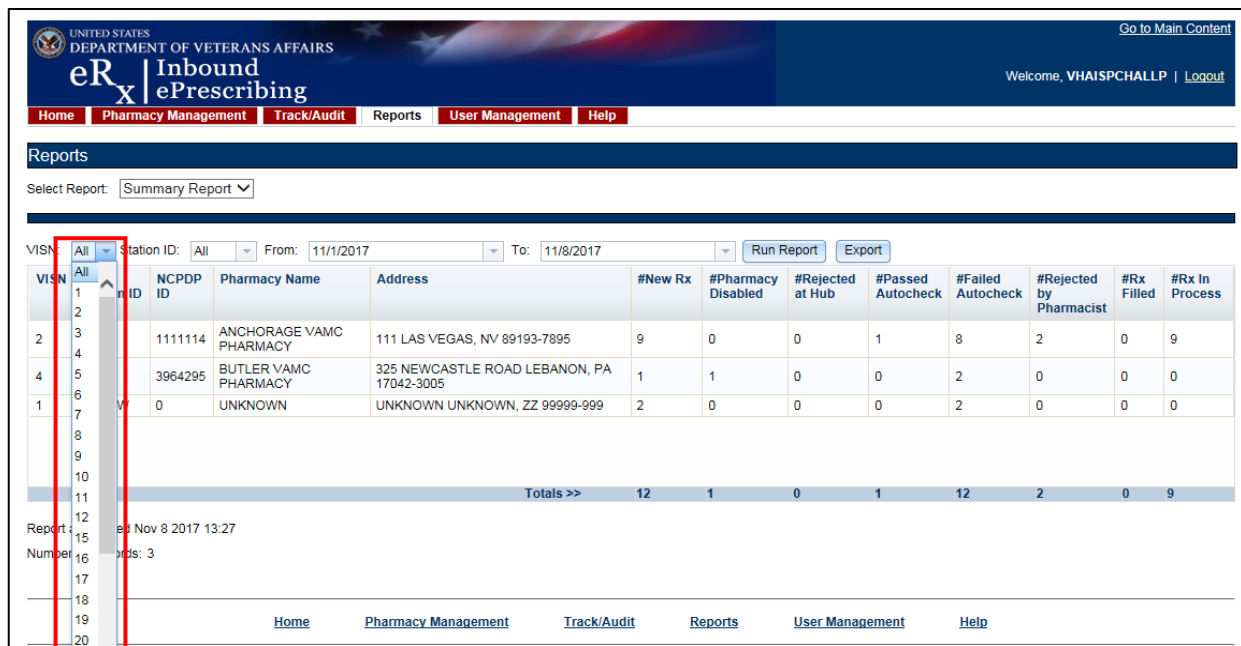
Reports

Select Report: Summary Report

VISN: All Station ID: All From: 11/1/2017 To: 11/8/2017 Run Report Export

VISN	VA Station ID	NCPDP ID	Pharmacy Name	Address	#New Rx	#Pharmacy Disabled	#Rejected at Hub	#Passed Autocheck	#Failed Autocheck	#Rejected by Pharmacist	#Rx Filled	#Rx In Process
2	984	1111114	ANCHORAGE VAMC PHARMACY	111 LAS VEGAS, NV 89193-7895	9	0	0	1	8	2	0	9
4	529	3964295	BUTLER VAMC PHARMACY	325 NEWCASTLE ROAD LEBANON, PA 17042-3005	1	1	0	0	2	0	0	0
1	UNKNW	0	UNKNOWN	UNKNOWN UNKNOWN, ZZ 99999-999	2	0	0	0	2	0	0	0
Totals >>					12	1	0	1	12	2	0	9

Report as of: Wed Nov 8 2017 13:27
 Number of Records: 3

Home Pharmacy Management Track/Audit Reports User Management Help

Figure 2-36: Reports Screen Filter Criteria - Select Station ID from Dropdown

- Select the date range from the Calendar drop down for the report or enter a date using the MM/DD/YYYY format.

UNITED STATES DEPARTMENT OF VETERANS AFFAIRS
eRx Inbound ePrescribing
 Home Pharmacy Management Track/Audit Reports User Management Help

Go to Main Content
 Welcome, VHAISPCHALLP | Logout

Reports

Select Report: Summary Report

VISN: All Station ID: All From: 11/1/2017 To: 11/8/2017 Run Report Export

VISN	VA Station ID	NCPDP ID	Pharmacy Name	Address	#New Rx	#Pharmacy Disabled	#Rejected at Hub	#Passed Autocheck	#Failed Autocheck	#Rejected by Pharmacist	#Rx Filled	#Rx In Process
2	984	1111114	ANCHORAGE VAMC PHARMACY	111 LAS VEGAS, NV 89193-7895	9	0	0	1	8	2	0	9
4	529	3964295	BUTLER VAMC PHARMACY	325 NEWCASTLE ROAD LEBANON, PA 17042-3005	1	1	0	0	2	0	0	0
1	UNKNW	0	UNKNOWN	UNKNOWN UNKNOWN, ZZ 99999-999	2	0	0	0	2	0	0	0
Totals >>					12	1	0	1	12	2	0	9

Report as of: Wed Nov 8 2017 13:27
 Number of Records: 3

Home Pharmacy Management Track/Audit Reports User Management Help

Figure 2-37: Reports Screen Filter Criteria - Select Date Range

- Select the **Run Report** button to generate the report.

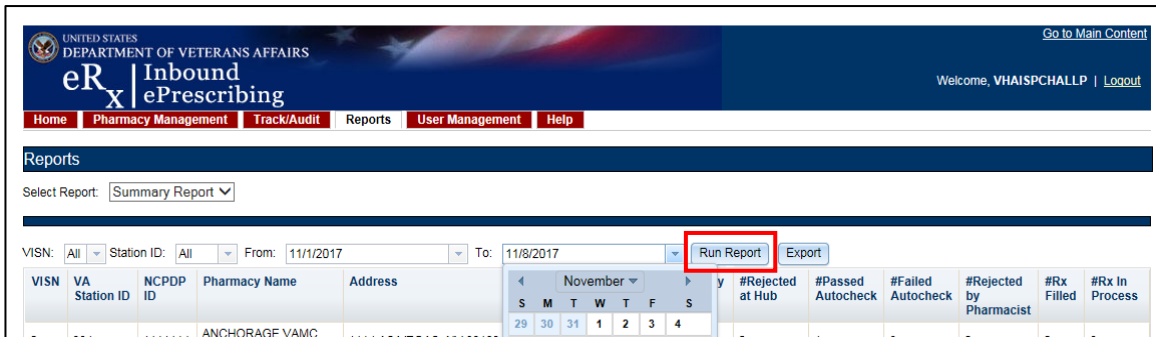

Figure 2-38: Run Report Button

6. Below are your summary report results.

VISN	VA Station ID	NCPDP ID	Pharmacy Name	Address	#New Rx	#Pharmacy Disabled	#Rejected at Hub	#Passed Autocheck	#Failed Autocheck	#Rejected by Pharmacist	#Rx Filled	#Rx In Process
2	984	1111114	ANCHORAGE VAMC PHARMACY	111 LAS VEGAS, NV 89193-7895	9	0	0	1	8	2	0	9

Figure 2-39: Summary Report Results

The Summary Report fields are described in the table below

Table 6: Summary Report Columns

Field	Description
VISN	Pharmacy VISN number
VA Station ID	VistA pharmacy identification number
NCPDP ID	National Council for Prescription Drug Programs (NCPDP) identification number
Pharmacy Name	VistA pharmacy name
Address	Pharmacy address
#New Rx	Number of New eRx's
#Pharmacy Disabled	Number of messages rejected because of the pharmacy not accepting eRx's (eRx's disabled)
#Rejected at Hub	Error messages sent from the Processing Hub to external provider
#Passed Autocheck	Number of eRx's that passed all autocheck criteria
#Failed Autocheck	Sum of failures for Patient, Provider, and Drug auto-validation checks
#Rejected by Pharmacist	Number of rejection messages sent by VistA
#Rx Filled	Number of RxFill messages received by the Processing Hub from VistA
#Rx In Process	Number of Inbound messages –(minus) number of failures and rejections –(minus) number filled.

Export Reports

From the Reports tab, users may export a report to a .CSV format.

To Export a report:

1. Select the **Export** button.



The screenshot shows a report interface with a table of data and a toolbar. The toolbar includes a 'Run Report' button and an 'Export' button, which is highlighted with a red box. The table below has the following data:

VISN	VA Station ID	NCPDP ID	Pharmacy Name	Address	#New Rx	#Pharmacy Disabled	#Rejected at Hub	#Passed Autocheck	#Failed Autocheck	#Rejected by Pharmacist	#Rx Filled	#Rx In Process
2	984	1111114	ANCHORAGE VAMC PHARMACY	111 LAS VEGAS, NV 89193-7895	9	0	0	1	8	2	0	9

Figure 2-40: Export Report Buttons

A prompt displays asking to Open or Save the report.

2. Select **Open** to view the report.
3. To save the report, select **Save**. The system displays a Save As dialog. Navigate to a location on your system to save the file.

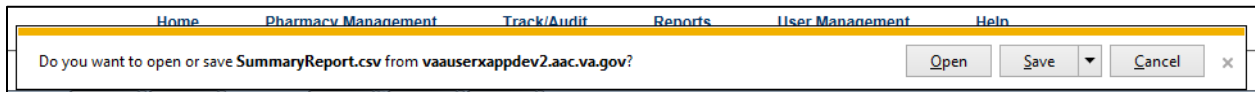

Figure 2-41: Summary Report Export Prompt (after clicking Export Button)

User Management

The User Management screen allows Administrators to add new users, delete users, and modify user roles. This screen will only display for users with Administrator access.

The User Management screen currently displays the list of all users that are added to this system along with their roles and privileges. Please note the user list is currently sorted by First Name.

Add New User

System Administrators have the ability to add new users from the User Management screen.

To add a new user:

1. Enter the new user's User ID, First Name, and Last Name.

Add User:

User ID: **(Required)**

First Name:

Last Name:

User Roles:

Figure 2-42: Add User - User ID, First Name, Last Name

2. Select the new user's role(s). Multiple roles may be selected by holding <Ctrl> while selecting more than one role.

Add User:

User ID: **(Required)**

First Name:

Last Name:

User Roles:

Figure 2-43: Add User - Select User Roles

3. Select **Save** to add the new user to the users list. To cancel adding a new user, select **Cancel**.

Add User:

User ID: (Required)

First Name:

Last Name:

User Roles:

Figure 2-44: Add User - Save and Cancel

Modify User Roles

System Administrators have the ability to modify user roles from the User Management screen. User roles include:

- Pharmacy Manager
- PBM Admin
- Pharmacy Tech
- Administrator

For further information on user roles and capabilities, please refer to the [Roles and Capabilities](#) section of this guide.

To modify user roles:

1. From the users list, locate the user and then select the checkbox(es) for the desired user role(s).

Delete Record	First Name	Last Name	User ID	Pharmacy Manager	PBM Admin	Pharmacy Tech	Administrator
<input type="checkbox"/>	TEST	USER	VHAISTESTUSER	<input type="checkbox"/>	<input checked="" type="checkbox"/>	<input type="checkbox"/>	<input checked="" type="checkbox"/>
<input type="checkbox"/>	TESTTWO	USER	VHAISTESTTWOSE	<input type="checkbox"/>	<input type="checkbox"/>	<input type="checkbox"/>	<input checked="" type="checkbox"/>

Figure 2-45: Select User Roles

2. Click **Save** at the bottom of the screen.
3. A message displays indicating that the user was updated successfully.

The Administrator may also select **Cancel** to cancel modifying user roles.

Delete Users

To delete a user from the application, locate a user in the user management table. Click the checkmark in the **Delete Record** column and click **Save**. A message displays indicating that the user's record was deleted successfully from the application.

Help Desk

For issues with the IEP Web-based application that cannot be resolved by this manual or the site administrator, please contact the National Service Desk at 855-NSD-HELP (673-4357) and reference "Inbound eRx".

Unit 3. **VistA Outpatient Pharmacy eRx Holding Queue**

Purpose

The VistA OP eRx Holding Queue allows VA Pharmacists and Pharmacy Technicians to validate and process Inbound eRx's from external providers. The eRx Holding Queue options are new options in the existing VistA OP system.

Setting Up Default eRx Clinic (Optional)

Sites are encouraged to edit their OUTPATIENT SITE file (#59) to define the default eRx clinic. The following field is added to the OUTPATIENT SITE file (#59): DEFAULT ERX CLINIC field (#10).

Please reference the Inbound ePrescribing VistA Patch # PSO*7.0*467 Implementation Guide on the VA Documentation Library (VDL) at the following link for details on setting up the default eRx clinic for a site.

Outpatient Pharmacy VDL URL: <https://www.va.gov/vdl/application.asp?appid=90>

Accessing the eRx Holding Queue

VA Pharmacies can only accept inbound eRx's through an eRx Processing Hub that interfaces to external providers capable of transmitting eRx's. The eRx message is transmitted from the Processing Hub to VistA OP and initially stored in the eRx Holding Queue.

The eRx Holding Queue is functionality in VistA OP that has been added for Inbound eRx processing. It allows for validation and review of eRx's by VA pharmacy users prior to the eRx being added to the VA record and merging with the existing outpatient functionality. VA Pharmacy users can validate patient, provider, drug/SIG information. Additionally users can accept, hold, print, reject, or remove an eRx's from the Holding Queue after it has been received by VistA from the eRx Processing Hub.

To access the eRx Holding Queue follows this navigation path:

Core Applications >> PS Pharmacy Menus >> Outpatient Pharmacy Manager >> (select Division) >> Rx (Prescriptions) ... >> Complete Orders from eRx [PSO ERX FINISH]

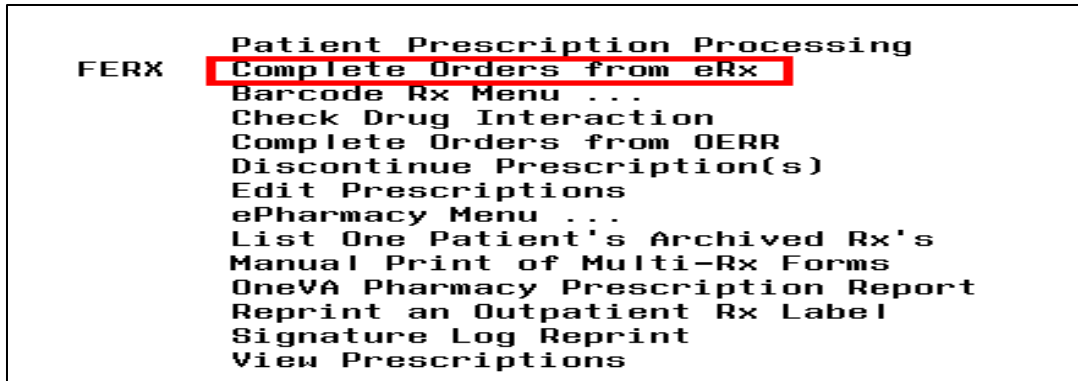

Figure 3-1: Complete Orders from eRx Menu Option

The first screen that displays upon accessing the eRx Holding Queue is the Holding Queue list screen.

PSO ERX HOLDING QUEUE		Nov 08, 2017@17:18:38		Page: 1 of 2	
Patient	DOB	Drug	Provider	STA	Rec Date
1. PATIENT,TEST		SILDENAFIL CITRATE 10	TEST PRESCR I		10/24/17
2. ZZERXCTF,FLORENCE		METHYLPREDN ACETATE 4	PROVIDER,ER I		10/24/17
3.		ASPIRIN 325MG TAB	BARHAN,MADH I		11/1/17
4.		METHYLPREDNISOLONE AC	PROVIDER,ER N		11/8/17
5.		METHYLPREDNISOLONE AC	PROVIDER,ER N		11/8/17
6.		CEFIXIME 200MG TAB	BARHAN,MADH N		11/8/17
7.		ACYCLOVIR 800MG TAB	ATKINS,ANTH N		11/8/17
8.		MELPHAALAN 2MG TAB	LEULU,LAURE N		11/8/17
9.		BENAZEPRIL HCL 20MG T	LEULU,LAURE N		11/8/17
10.		TRIFLUOPERAZINE 5MG T	LEULU,LAURE N		11/8/17
11.		RISEDRONATE NA 35MG T	LEULU,LAURE N		11/8/17
12.		ACETAZOLAMIDE 250MG T	LEULU,LAURE N		11/8/17
13.		CETIRIZINE HCL 10MG T	LEULU,LAURE N		11/8/17
14.		GAUZE PAD 2IN X 2IN S	ALBRECHT,AL N		11/8/17
15.		DIAPER ADULT MEDIUM	TILGH,JOHNI N		11/8/17

* Enter ?? for more actions
 SI Select Item
 SR Search Queue
 SO Sort Entries
 Select Action:Next Screen//

Figure 3-2: eRx Holding Queue List

eRx Holding Queue List View

The eRx Holding Queue list columns include the patient's name (Patient), date of birth of the patient (DOB), the prescribed drug from the external provider (Drug), the prescribing physician's name (Provider), the status of the eRx (STA), and the date that the eRx was received by VistA (Rec Date). At any given time, 999 eRx records are displayed in the Holding Queue list view with statuses of "N", "I" or with one of the Hold codes. The records are sorted by Received Date with oldest records first. (Refer to [Appendix A. Holding Queue Status Codes & Descriptions](#) for more information on the various statuses in the list.)

The following actions are available from the eRx Holding Queue list:

- **<SI> Select Item** can be entered to select an item in the Enter a Number prompt. Additionally, the record # can be entered without selecting SI at the “Select Action: Next Screen//” prompt.
- **<SR> Search Queue** can be entered to search for an eRx based on a variety of search criteria. Refer to the [Search eRx_s](#) section.
- **<SO> Sort Entries** can be entered to sort the list. Refer to the [Sorting eRx_s](#) section.

Note that the default sort order on the initial list display is the following:

- Date Received - Oldest to Newest
- Secondary sort by Patient Name

PSO ERX HOLDING QUEUE		Nov 08, 2017@17:18:38		Page: 1 of 2	
Patient	DOB	Drug	Provider	STA	Rec Date
1. PATIENT,TEST		SILDENAFIL CITRATE 10	TEST PRESCR	I	10/24/17
2. ZZERXCTF,FLORENCE		METHYLPREDN ACETATE 4	PROVIDER,ER	I	10/24/17
3.		ASPIRIN 325MG TAB	BARHAN,MADH	I	11/1/17
4.		METHYLPREDNISOLONE AC	PROVIDER,ER	N	11/8/17
5.		METHYLPREDNISOLONE AC	PROVIDER,ER	N	11/8/17
6.		CEFIXIME 200MG TAB	BARHAN,MADH	N	11/8/17
7.		ACYCLOVIR 800MG TAB	ATKINS,ANTH	N	11/8/17
8.		MELPHAALAN 2MG TAB	LEULU,LAURE	N	11/8/17
9.		BENAZEPRIL HCL 20MG T	LEULU,LAURE	N	11/8/17
10.		TRIFLUOPERAZINE 5MG T	LEULU,LAURE	N	11/8/17
11.		RISEDRONATE NA 35MG T	LEULU,LAURE	N	11/8/17
12.		ACETAZOLAMIDE 250MG T	LEULU,LAURE	N	11/8/17
13.		CETIRIZINE HCL 10MG T	LEULU,LAURE	N	11/8/17
14.		GAUZE PAD 2IN X 2IN S	ALBRECHT,AL	N	11/8/17
15.		DIAPER ADULT MEDIUM	TILGH,JOHNI	N	11/8/17

Enter ?? for more actions

SI Select Item
 SR Search Queue
 SO Sort Entries
 Select Action:Next Screen//

Figure 3-3: eRx Holding Queue List View

eRx Holding Queue Summary Screen

A user can select a record from the eRx Holding Queue List View by both typing <SI> and the record number or by typing the record number itself. The first screen displayed is the Summary Screen, which displays information about the original eRx from the external provider and matched VistA information (if any).

On this screen, the header contains the eRx Patient Name and eRx Reference #, which is an internal VA reference number assigned for tracking the eRx. Below the header is information received from the external provider for the patient, provider, and the drug/SIG. Where applicable, VistA information displays below the eRx information.

Press <Enter> to display Page 2 of the Summary Screen, which contains Hold Reason, Placed on hold by, and eRx Notes fields. Diagnosis information is displayed at the bottom of the Summary screen.

```

PSO ERX PATIENT VALIDATION      Nov 08, 2017@17:26:41      Page: 1 of 1
eRx Patient: [REDACTED], LYDIA
eRx Reference #: 10725

eRx Patient: [REDACTED], LYDIA
Sex: FEMALE                      DOB: [REDACTED]
Addr: [REDACTED]                 SSN: [REDACTED]
City: TAMPA                      St: FLORIDA      Zip: 34655
Home Phone: [REDACTED]           Cell Phone: [REDACTED]

-----
Status: NOT VALIDATED
PATIENT NOT MATCHED

-----
Enter ?? for more actions
P Print          H Hold          UH Un Hold
E Edit           AV Accept Validation  RJ Reject
Select Item(s): Edit// █

```

```

eRx Holding Queue Display      Nov 08, 2017@17:23:51      Page: 2 of 3
eRx Patient: [REDACTED], LYDIA
eRx Reference #: 10725
+
Hold Reason:
Placed on hold by:

eRx Notes: Authorizing refills. Patient must make appointment

Diagnosis Sequence: 1
Primary DX Qualifier: ICD-10-CM
Primary Dx Value: PRIMARYDIAGCODE.1

Secondary DX Qualifier: ICD-9-CM
Secondary Dx Value: SECOND.DIAGCODE.1

Diagnosis Sequence: 2
Primary DX Qualifier: ICD-9-CM
Primary Dx Value: PRIMARYDIAGCODE.2
+
Enter ?? for more actions
VP VALIDATE PATIENT      VM VALIDATE PROVIDER      VD (VALIDATE DRUG/SIG)
P Print                  RJ Reject                  AC Accept eRx
H Hold                   UH Un Hold                 RM Remove eRx
Select Item(s): Next Screen// █

```

```

eRx Holding Queue Display      Nov 08, 2017@17:24:26      Page: 3 of 3
eRx Patient: [REDACTED], LYDIA
eRx Reference #: 10725
+
Secondary DX Qualifier: ICD-10-CM
Secondary Dx Value: SECOND.DIAGCODE.2

-----
Enter ?? for more actions
VP VALIDATE PATIENT      VM VALIDATE PROVIDER      VD (VALIDATE DRUG/SIG)
P Print                  RJ Reject                  AC Accept eRx
H Hold                   UH Un Hold                 RM Remove eRx
Select Item(s): Quit//

```

Figure 3-4: Summary Screens

If the VistA information for the patient, provider, or drug is not linked, the display would be as shown below:

- VistA Patient: NOT LINKED
- VistA Provider: NOT LINKED
- VistA Drug: NOT LINKED

eRx Actions

- Manual Validation:
 - <VP> Validate Patient
 - <VM> Validate Provider
 - <VD> (Validate Drug/SIG) - Note that this action is not be available unless a VistA patient has been linked, as indicated with parenthesis around the action
- <AC> [Accept eRx](#): Action is not available until the validation of the eRx Patient, provider, and drug/SIG have been completed. Also note that the <AC> action will not be available if the eRx is on Hold.
- <RJ> [Rejecting eRx](#)s: Rejects an eRx
- <P> [Print](#): Displays all details of an eRx and allows the user to select a local printer and print the eRx
- <H> [Hold](#): Place an eRx on Hold
- <UH> [Un Hold](#): Remove eRx from a Hold
- <RM> [Removing eRx](#)s: Removes eRx from the main list display and prevents further processing of the eRx
- <??> For hidden actions. For more details on the above actions, please refer to the sections identified.

NOTE: From the Summary Screen, users cannot edit any of the VistA information. The validate screens contain the option for editing the VistA information. For further information on editing and validating VistA information for an eRx, please refer to the [Manual Validation](#) section.

Patient-Level Record Lock

Note that when either the Summary screen or any of the validate screens of an eRx are open, all of the eRx's for that same patient in the Holding Queue are locked and inaccessible for other users to access until the lock is released (the screens are closed). This is referred to as a patient-level record lock.

The following message displays if a user attempts to access an eRx for the same patient that another user has opened.

```
TEST PHARMACIST, ERX is editing orders for this patient (AUG 18,2017@14:59:09)
Type <Enter> to continue or '^' to exit: █
```

Figure 3-5: Patient-Level Record Lock

Manual Validation

Prior to accepting an eRx (AC) and moving the eRx to Pending Outpatient Orders file, the VistA patient, provider, and drug/SIG must be validated. The eRx will then be further processed using Patient Prescription Processing [PSO LM BACKDOOR ORDERS] or Complete Orders from OERR [PSO LMOE FINISH].

The validation process begins by selecting one of the validate actions from the Summary screen.

NOTE: Before the Drug/SIG on an eRx can be manually validated, the eRx Patient must have a linked VistA patient. The <VD> (Validate Drug/SIG) action will have parenthesis around the action to signify this action is not available until a VistA patient is linked as illustrated in the figure below.

```
eRx Holding Queue Display      Nov 08, 2017@17:23:04      Page: 1 of 3
eRx Patient: ██████████ LYDIA
eRx Reference #: 10725

eRx Patient: ██████████ LYDIA          DOB: ██████████
Vista Patient: NOT LINKED             DOB: ██████████

eRx Provider: LEULU,LAUREN A         NPI: 2445698197
Vista Provider: NOT LINKED           NPI: N/A

eRx Drug: MELPHAALAN 2MG TAB
eRx Qty: 60          eRx Refills: 0   eRx Days Supply: 30   eRx Date: NOV 08, 2017
eRx Sig: TAKE ONE TABLET BY MOUTH 2 FOR 5 DAYS

Vista Drug: NOT LINKED
Vista Qty: 60          Vista Refills: 0       Vista Days Supply: 30
Vista Sig:
Pat Inst:
Hold Status:

+ Enter ?? for more actions
VP VALIDATE PATIENT      VM VALIDATE PROVIDER      VD (VALIDATE DRUG/SIG)
P Print                  RJ Reject                  AC Accept eRx
H Hold                   UH Un Hold                 RM Remove eRx
Select Item(s): Next Screen// █
```

Figure 3-6: Summary Screen Actions

Validate Patient

The patient must be validated before an eRx can be accepted. Refer to [Accept eRx](#). Information about the Patient Validation screen and editing the patient information is described in the following sections.

To validate patient information, type <VP> VALDIATE PATIENT from the Summary screen. The Patient Validation screen displays and is described in the following sections.

```
+-----Enter ?? for more actions-----+
VP VALIDATE PATIENT          VM VALIDATE PROVIDER      VD VALIDATE DRUG/SIG
P  Print                    RJ Reject              AC Accept eRx
H  Hold                     UH Un Hold        RM Remove eRx
Select Item(s): Next Screen// VP  VALIDATE PATIENT
```

Figure 3-7: Validate Patient

Patient Auto-Match in the Processing Hub

The following outlines the scenarios for a patient auto-match in the IEP Processing Hub before being sent down to VistA:

Patient Match - Primary Hub

1. MVI Check - receive ICN and SSN from MVI if successful
 - a. If SSN is sent on a new eRx (NEWRX), then the SSN will be used in the auto-match with the MVI along with Last Name, First Name, DOB, Gender, Address Line 1, and Home Telephone Number
 - b. If SSN is not sent on the NEWRX, then the match will be done with MVI against Last Name, First Name, DOB, Gender, Address Line 1, and Home Telephone Number
 - c. Since only the Last Name, First Name, DOB, and Gender are mandatory on a NEWRX, the match will be done against all of the data pieces that are received
 - d. When a patient is successfully matched, the patient registration at the sites will be checked.
2. E&E Check - Then E&E Services is checked to see if the patient is both enrolled and eligible to their system to receive pharmacy benefits (This is done using ICN retrieved from MVI)

Patient Secondary Match in VistA

- Case 1: Patient Automatch successful (MVI record found, E&E check passed and Patient Site Registration passed)
 - a. Use the ICN received from MVI and check against the local Patient file entry; if passed, then link this VistA patient to eRx Patient
 - b. If ICN check fails, use the SSN received from MVI and check against the local Patient file entry; if passed, then link this VistA patient to eRx Patient

- Case 2: MVI Match successful but E&E check failed at the Hub:
 - a. Use the ICN received from MVI and check against the local Patient file entry; if passed, then link this VistA patient to eRx Patient
 - b. If ICN check fails, use the SSN received from MVI and check against the local Patient file entry; if passed, then link this VistA patient to eRx Patient
- Case 3: MVI match unsuccessful at the Hub
 - a. No secondary match

Patient Manual Validation Screen Overview

The header of the Patient Validation screen contains the eRx Patient Name and the eRx Reference #. Below the header is the eRx and VistA information for the patient, where applicable.

NOTE: The eRx Patient information is display-only and cannot be edited.

If a match was NOT found for the eRx Patient, the screen looks similar to the below figure. The Status field has “NOT VALIDATED”, with “PATIENT NOT MATCHED” below the Status. No VistA patient information displays.

The screenshot shows a terminal-style interface for 'PSO ERX PATIENT VALIDATION'. At the top, it displays the date and time 'Nov 08, 2017@17:26:41' and 'Page: 1 of 1'. The patient information includes: eRx Patient: LYDIA, eRx Reference #: 10725, eRx Patient: LYDIA, Sex: FEMALE, DOB: [redacted], SSN: [redacted], Addr: [redacted], City: TAMPA, St: FLORIDA, Zip: 34655, Home Phone: [redacted], and Cell Phone: [redacted]. A red box highlights the status: 'Status: NOT VALIDATED' and 'PATIENT NOT MATCHED'. At the bottom, there is a menu with options: P Print, E Edit, H Hold, AV Accept Validation, UH Un Hold, and RJ Reject. A prompt 'Enter ?? for more actions' is also visible.

Figure 3-8: Patient Validation Screen Display - Patient Not Validated/ Not Auto Matched

If a match is found, however, the patient has NOT been validated, the Summary screen looks similar to the screen in the below figure. The Status field has “NOT VALIDATED”, with VistA information displaying, where applicable.

```

PSO_ERX_PATIENT_VALIDATION Nov 08, 2017@17:28:28 Page: 1 of 1
eRx Patient: Test Patient 1
eRx Reference #: 10723

eRx Patient: Test Patient 1
Sex: MALE DOB: [REDACTED]
SSN: [REDACTED]
Addr: [REDACTED]
City: NEW PORT RICHEY St: FLORIDA Zip: 34655
Home Phone: [REDACTED] Cell Phone: [REDACTED]

Status: NOT VALIDATED
Vista Patient: Test Patient 1
Sex: MALE [REDACTED]
Addr: [REDACTED]
City: NEW PORT RICHEY St: FLORIDA Zip: 34655
Home Phone: [REDACTED] Cell Phone: [REDACTED]

Eligibility: SERVICE CONNECTED 50% to 100%
Pharmacy Narrative: test

Enter ?? for more actions
P Print H Hold UH Un Hold
E Edit AV Accept Validation RJ Reject
Select Item(s): Quit//

```

Figure 3-9: Patient Validation Screen Display - Patient Not Validated / Patient Auto Matched

If the patient has been validated, the Status field above the VistA Patient contains “VALIDATED”, with the user who performed the validation and date/timestamp.

```

PSO_ERX_PATIENT_VALIDATION Nov 08, 2017@17:32:20 Page: 1 of 1
eRx Patient: Test Patient 1
eRx Reference #: 10723

eRx Patient: Test Patient 1
Sex: MALE DOB: [REDACTED]
SSN: [REDACTED]
Addr: [REDACTED]
City: NEW PORT RICHEY St: FLORIDA Zip: 34655
Home Phone: [REDACTED] Cell Phone: [REDACTED]

Status: VALIDATED (CHALLAGUNDLA,PRAVEEN - NOV 08, 2017@17:32:16)
Vista Patient: Test Patient 1
Sex: MALE DOB: [REDACTED]
SSN: [REDACTED]
Addr: [REDACTED]
City: NEW PORT RICHEY St: FLORIDA Zip: 34655
Home Phone: [REDACTED] Cell Phone: [REDACTED]

Eligibility: SERVICE CONNECTED 50% to 100%
Pharmacy Narrative: test

Enter ?? for more actions
P Print H Hold UH Un Hold
E Edit AV Accept Validation RJ Reject
Select Item(s): Quit//

```

Figure 3-10: Patient Validated

The actions at the bottom of the Patient Validation screen include:

- <P> Print – Prints display of the eRx for printing to network or local printer.
- <H> Hold – Places an eRx on hold.
- <UH> Un Hold – Removes an eRx from a Hold
- <E> Edit – User edits if the information is empty or incorrect
- <AV> Accept Validation – User accepts the validation if information is correct
- <RJ> Reject – Rejects the eRx

Edit Patient

1. Enter <E> Edit to edit the patient information.
2. If a VistA patient already exists for the eRx, the system displays a message confirming the edit.

```
A patient has already matched to a vista patient.  
Would you like to edit the patient? NO//
```

Figure 3-11: Edit Patient on a VistA Match

3. If a VistA patient match does not exist, the system prompts to select a patient at the “Select Patient Name” prompt. The partial or full name of the patient, DOB or SSN can be entered.
4. Select the correct patient and press <Enter>.
5. A message displays confirming the patient selection. Enter <Y> Yes.
6. The select patient information populates the VistA Patient fields on the Patient Validation screen.

NOTE: A Warning Message displays if there is a DOB, Gender, and/or a SSN mismatch on the patient selected during the edit process.

```
*****WARNING*****  
SSN mismatch.  
Date of Birth mismatch.  
Gender mismatch.  
*****
```

Figure 3-12: Mismatch Warning Message

Accept Patient Validation

Once the patient information has been edited and reviewed for accuracy, the validation needs to be accepted on the Patient Validation screen.

1. Select <AV> Accept Validation on the Patient Validation screen to accept the provider validation.
2. A message displays confirming whether or not to mark the patient as validated. Enter <Y> Yes.

If the validation is successful, a message displays indicating that the validation was updated.

The Status changes to “VALIDATED” on the Patient Validation screen, along with the user who performed the validation and date/timestamp.

```

Would you like to mark this patient as VALIDATED?
Enter Yes or No: NO// YES
Validation Updated!!
Type <Enter> to continue or '^' to exit:

```

Figure 3-13: Confirm Acceptance of Patient Validation

A “[v]” displays to the right of the Vista Patient field on the Summary screen.

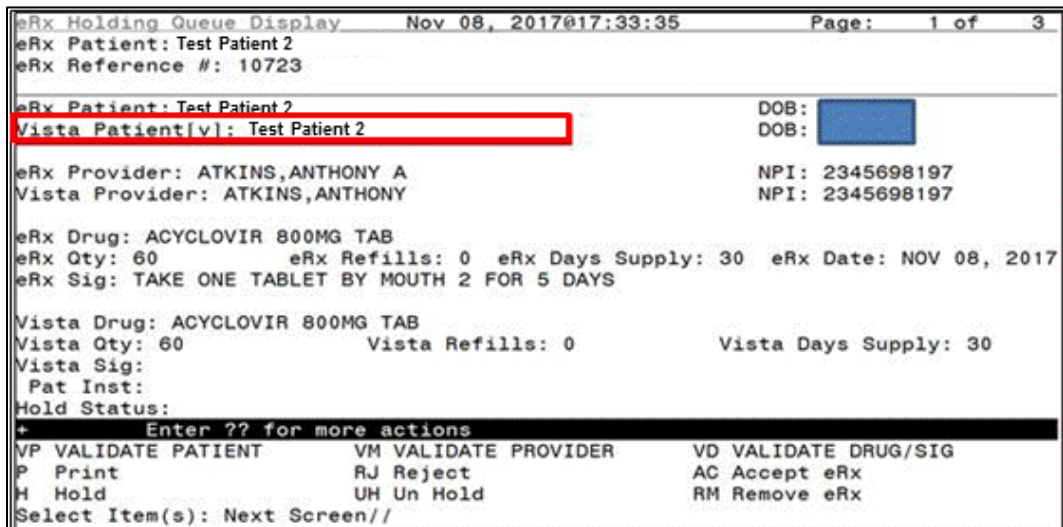

Figure 3-14: Patient Validation Complete: Summary Screen Indicator

Automatic Patient Validation

When a patient validation is accepted on one eRx and there are additional eRx's in the Holding Queue for the same patient, received on the same day, a message displays asking if the patient validation should be applied to the other eRx's. (Refer to the figure below.) If the user selects <Y> Yes, the system links and applies the patient validation for the eRx's currently in the Holding Queue for that patient.

The determination of the same patient is based on unique records from the ERX EXTERNAL PATIENT file (#52.46). The system will only validate the same patients on eRx's that are currently in the ERX HOLDING QUEUE file (#52.49) received at the time of the automatic patient validation. Patient validation will not be applied for eRx's received for that patient after the autovalidation is applied. For example, if VA receives six eRx's for the same patient on the same day, the user will only have to validate the patient once. If eRx's are received later that same day, those eRx's will need to be revalidated.

```

This patient has other prescriptions for: Nov 08, 2017
Patient: TestPatient2

```

DRUG	PROVIDER	REC DATE
1.) ACYCLOVIR 800MG TAB	ATKINS,ANTHONY A	NOV 08, 2017

Figure 3-15: Automatic Patient Validation

To apply patient validation to other eRx's in the Holding Queue for the same patient, received on the same day:

1. The system asks the user if the previous validation should be applied to the other eRx's received for the patient.

```

Would you like apply the above validation to these prescriptions?
Enter Yes or No: N//

```

Figure 3-16: Apply Patient Validation to Other eRx's

2. Enter **Y** for Yes to apply the validation to the other eRx's for the patient. After selecting Yes, the patient validation is applied to the other eRx's. As previously noted, any eRx's received after this action will not be validated.
3. A message displays indicating that the validation was updated.
4. A "[v]" displays to the right of the VistA Patient field on the Summary screen and the Status field changes to "VALIDATED" on the Patient Validation screen, along with the user who performed the validation and date/timestamp. This occurs for all of the eRx's validated via the automatic patient validation process.
5. The statuses on all eRx's validated by the automatic patient validation process will change to "I" for In Process.

Validate Provider

The provider must be validated before an eRx can be accepted.

To validate provider information, from the Summary screen, type <VM> VALIDATE PROVIDER. The eRx Provider Validation screen displays.

```

+-----Enter ?? for more actions-----+
VP VALIDATE PATIENT          VM VALIDATE PROVIDER          VD VALIDATE DRUG/SIG
P Print                      RJ Reject                      AC Accept eRx
H Hold                       UH Un Hold                    RM Remove eRx
Select Item(s): Next Screen// VM VALIDATE PROVIDER

```

Figure 3-17: Summary Screen Action - Validate Provider

Information about the Validate Provider display and editing the provider information is described in the following sections.

Provider Auto-Match in the Processing Hub

The auto-match on an external provider is based upon the NPI of the prescriber coming in on the new eRx. The NPI is matched against the VistA instance's NEW PERSON file (#200) entry. If the NPI matches and if the Provider is marked 'Authorized to Write Meds' that is considered as a match. Upon successful match, the VistA provider is linked with the incoming provider's record in VistA.

Provider Manual Validation Screen Overview

The header of the Provider Validation screen contains the eRx Patient Name and the eRx Reference #. Below the header is the eRx and VistA information for the provider, where applicable.

NOTE: The eRx provider information is display-only and cannot be edited.

If a match was NOT found for the eRx provider, the screen looks similar to the below figure. The Status field has "NOT VALIDATED", with "PROVIDER NOT MATCHED" below the Status. No provider information displays.

The screenshot displays the 'PSO ERX PROVIDER VALIDATION' screen. At the top, it shows the date and time 'Nov 08, 2017@17:38:12' and 'Page: 1 of 1'. The patient information includes 'eRx Patient: [REDACTED] YDIA' and 'eRx Reference #: 10725'. The provider information lists 'eRx Provider: LEULU, LAUREN A' and 'Address: [REDACTED]'. Further details include 'Newton, INDIANA 23456', 'NPI: 2445698197', 'DEA: CT9012345', 'State Lic: ABC4567777', 'Tel: 1113334321X1234', 'Fax: 1112224321', 'Agent: CHALLAGUNDLA, PRAVEEN', and 'Supervisor: SUPERVISOR LAST NAME POPULAT'. A red box highlights the status: 'Status: NOT VALIDATED' and 'PROVIDER NOT MATCHED'. At the bottom, there is a menu with options: 'P Print', 'E Edit', 'H Hold', 'AV Accept Validation', 'UH Un Hold', and 'RJ Reject'. The prompt 'Enter ?? for more actions' is also visible.

Figure 3-18: Provider Not Auto Matched / Not Validated

Edit Provider

To edit the provider information:

1. Press the <E> Edit action on the Provider Validation screen.
2. If no VistA provider information is in the system for the eRx, the "Select Provider Name" prompt displays for searching for and selecting a provider.
 - a. Enter either the partial name or full name of the provider or the NPI of the Provider, or DEA of the Provider at the "Select Provider Name" prompt. If multiple providers exist with the same name exist, a list of providers is provided with additional

- identifying information (e.g., middle initial, mail code, and title, where applicable, etc.).
- b. Select the provider.
- 3. If a VistA provider is currently linked for the eR_x, the system asks if the current provider should be modified.
 - a. Enter <Y> Yes.
 - b. Enter either the partial name or full name of the provider at the “Select Provider Name” prompt.
 - c. Select the provider.

```

Select Item(s): Next Screen// E Edit
Current Vista provider: TEST PRESCRIBER, ERX

Would you like to modify the current provider? NO//

```

Figure 3-19: Modify Current VistA Provider

- 4. Once the VistA provider is selected, the VistA provider fields populate on the Provider Validation screen, along with information whether the DEA of the Provider has expired or not.
- 5. The next step in in the provider validation process is to accept the validation, which is described in the next section.

Accept Provider Validation

Once the correct provider has been selected and reviewed for accuracy, the next step is to accept the validation using the following steps.

- 1. Select <AV> ACCEPT VALIDATION on the Provider Validation screen to accept the provider validation.

NOTE: The following warning message displays upon selecting the validation if there is a DEA # and/or NPI mismatch.

```

*****WARNING*****
Provider NPI Mismatch.
Provider DEA Mismatch.
*****

```

Figure 3-20: Select Provider Warning Message

A message displays confirming whether or not to mark the provider as validated.

- 2. Enter <Y> Yes.
- 3. If the validation is successful, a message displays indicating that the validation was updated. Type <Enter> to continue or '^' to Quit.

NOTE: If there are other eRx's for the patient, written by the same provider, received on the same day for that patient, a message displays asking if the provider validation should be applied to those eRx's. Refer to the [Automatic Provider Validation](#) section for more information.

- The Status field changes to “VALIDATED” on the Provider Validation screen and the user who accepted the validation and date/timestamp displays to the right of “VALIDATED”.
- A “[v]” displays to the right of the VistA Provider field on the Summary screen.

```

PSO_ERX_PROVIDER_VALIDATION Nov 08, 2017@17:41:45 Page: 1 of 1
eRx Patient: ██████████
eRx Reference #: 10723

eRx Provider: ATKINS,ANTHONY A
Address: ██████████
          Newton, INDIANA 23456
NPI: 2345698197 DEA: AT9012345 State Lic: ABC4567777
Tel: 1113334321X1234 Fax: 1112224321
Agent: CHALLAGUNDLA, PRAVEEN Supervisor: SUPERVISOR LAST NAME POPULAT
-----
Status: NOT VALIDATED
Vista Provider: ATKINS,ANTHONY
Address: ██████████
          DUNEDIN, FLORIDA 34698
NPI: 2345698197 DEA: AT9012345
Tel: ██████████ Fax: ██████████

Enter ?? for more actions
P Print H Hold UH Un Hold
E Edit AV Accept Validation RJ Reject
Select Item(s): Quit//
  
```

Figure 3-21: Before Provider Validation (Validate Provider Screen)

```

PSO_ERX_PROVIDER_VALIDATION Nov 08, 2017@17:42:49 Page: 1 of 1
eRx Patient: ██████████
eRx Reference #: 10723

eRx Provider: ATKINS,ANTHONY A
Address: ██████████
          Newton, INDIANA 23456
NPI: 2345698197 DEA: AT9012345 State Lic: ABC4567777
Tel: 1113334321X1234 Fax: 1112224321
Agent: CHALLAGUNDLA, PRAVEEN Supervisor: SUPERVISOR LAST NAME POPULAT
-----
Status: VALIDATED (CHALLAGUNDLA,PRAVEEN - NOV 08, 2017@17:42:45)
Vista Provider: ATKINS,ANTHONY
Address: ██████████
          DUNEDIN, FLORIDA 34698
NPI: 2345698197 DEA: AT9012345
Tel: ██████████ Fax: ██████████

Enter ?? for more actions
P Print H Hold UH Un Hold
E Edit AV Accept Validation RJ Reject
Select Item(s): Quit//
  
```

Figure 3-22: After Provider Validation (Validate Provider Screen)

```

eRx Holding Queue Display      Nov 08, 2017@17:58:18      Page: 1 of 3
eRx Patient: [REDACTED]
eRx Reference #: 10723
-----
eRx Patient: [REDACTED]
Vista Patient[v]: [REDACTED]
eRx Provider: ATKINS,ANTHONY A
Vista Provider[v]: ATKINS,ANTHONY
DOB: [REDACTED]
DOB: [REDACTED]
NPI: 2345698197
NPI: 2345698197
eRx Drug: ACYCLOVIR 800MG TAB
eRx Qty: 60      eRx Refills: 0      eRx Days Supply: 30      eRx Date: NOV 08, 2017
eRx Sig: TAKE ONE TABLET BY MOUTH 2 FOR 5 DAYS
Vista Drug: ACYCLOVIR 800MG TAB
Vista Qty: 60      Vista Refills: 0      Vista Days Supply: 30
Vista Sig:
Pat Inst:
Hold Status:
* Enter ?? for more actions
VP VALIDATE PATIENT      VM VALIDATE PROVIDER      VD VALIDATE DRUG/SIG
P Print      RJ Reject      AC Accept eRx
H Hold      UH Un Hold      RM Remove eRx
Select Item(s): Next Screen//

```

Figure 3-23: After Provider Validation (Summary Screen)

Automatic Provider Validation

When a provider validation is accepted on one eRx and there are additional eRx s in the Holding Queue for the same patient by the same provider, received on the same day, a message displays asking if the other eRx s for the patient written by the provider should be validated. If the user selects <Y> Yes, the system links and applies the provider validation for the eRx s currently in the Holding Queue for the patient by the same provider.

The determination of the same provider is based on unique records from the ERX EXTERNAL PERSON file (#52.48). The system only validates the same provider on eRx s that are currently in the ERX HOLDING QUEUE file (#52.49) for the same patient received on the same date. Provider validation is not applied for the same provider received after the autovalidation is applied once. For example, if VA receives six eRx s for the same patient on the same day from the same provider, the user only has to validate the provider once; however, if eRx s are received after the automatic provider validation is applied (e.g., later that same day by that provider), the provider for those eRx s needs to be validated.

```

There are other prescriptions for this patient, written by this provider on
Nov 08, 2017
Provider: ATKINS,ANTHONY A
Patient: [REDACTED]
-----
DRUG                PROVIDER                REC DATE
-----
1.) ACYCLOVIR 800MG TAB    ATKINS,ANTHONY A        NOV 08, 2017
-----
Would you like apply the above validation to these prescriptions?
Enter Yes or No: N// 0

```

Figure 3-24: Automatic Provider Validation

To apply the provider validation to the other eRx s enter <Y> Yes. A message displays indicating that the validation was updated.

- The Status field on all of the eR_xs, where the provider validation has been applied, changes to “VALIDATED” on the Provider Validation screen and the user who accepted the validation and date/timestamp displays to the right of “VALIDATED”.
- A “[v]” displays to the right of the VistA Provider field on the Summary screen.
- The statuses on all eR_xs validated by the automatic provider validation process will change to “I” for In Process.

Validate Drug/SIG

The drug/SIG information on the eR_x must be validated before an eR_x can be accepted.

NOTE: A VistA patient must be linked (matched) before the Validate Drug/SIG action will be available.

To validate drug/SIG information for the eR_x, type <VD> Validate Drug/SIG from the Summary screen. The Drug Validation screen displays and is described in the following sections.

```
+-----Enter ?? for more actions-----+
VP VALIDATE PATIENT          VM VALIDATE PROVIDER          VD VALIDATE DRUG/SIG
P  Print                    RJ Reject                    AC Accept eRx
H  Hold                     UH Un Hold                    RM Remove eRx
Select Item(s): Next Screen// VD VALIDATE DRUG/SIG
```

Figure 3-25: Validate Drug / SIG

Drug Auto-Match in the Processing Hub

The pre-conditions for a drug auto-match in the Processing Hub are that the drug should be one-to-one match, should not be a Compound, not a Controlled Substance, should be Active, not Investigational and should be marked for Outpatient use in the local DRUG file (#50).

First, the drug description on the new eR_x is matched against the Drug Generic Name entry in the VistA instance’s DRUG file (#50). If successful, the match stops right here and the drug is linked in VistA.

If the match is not successful, the drug description is then matched against the VA Product Name entry in the VistA instance’s VA PRODUCT file (#50.68). Then a drug in local file for the matched VA Product Name is identified, which should satisfy the preconditions. If the match is successful, the drug is linked in VistA.

If the match is not successful, the NDC is used to match against the VistA instance’s NDC/UPN file (#50.67). Using the VA Product Name identified at this step, a drug in the local file for the matched VA Product Name is identified, which should satisfy the preconditions. If the match is successful, the drug is linked in VistA.

NOTE: The NDC is an optional field and may or may not be included with the new eR_x. For a supply, if UPC is sent, it is not matched against the NDC/UPN File #50.67. Only the Drug Description match is attempted.

Drug/SIG Manual Validation Screen Overview

The header of the Drug/SIG Validation screen contains the eRx Patient Name and the eRx Reference #. Below the header is the eRx and VistA information for the drug/SIG, where applicable.

NOTE: The eRx drug/SIG information is display-only and cannot be edited.

If a match was NOT found for the VistA drug, the screen looks similar to the below figure. The Status field has “NOT VALIDATED”, with “NOT MATCHED” to the right of the VistA Drug field. The other VistA drug/SIG fields may or may not be populated.

```
PSO ERX DRUG VALIDATION      Nov 08, 2017@17:47:53      Page: 1 of 2
eRx Patient [REDACTED]
eRx Reference #: 10725

eRx Drug: MELPHAALAN 2MG TAB
Qty: 60                      Days Supply: 30          Date Written: NOV 08, 2017

Qty Qualifier: QUANTIFY SUFFICIENT
Drug Form: Orally Disintegrating Tablet Dosage Form
Strength: Microgram per Fifteen Milliliters
Potency Unit Code: International Unit

Refills: 0                   Do not sub: NO PRODUCT SELECTION INDICATED
eRx Sig: TAKE ONE TABLET BY MOUTH 2 FOR 5 DAYS
eRx Notes: Authorizing refills. Patient must make appointment

-----
Status: NOT VALIDATED
(1) VistA Drug: NOT MATCHED
(2) [REDACTED]

+ Enter ?? for more actions
P Print                      H Hold                      UH Un Hold
E Edit                       AV Accept Validation       RJ Reject
Select Item(s): Edit//
```

Figure 3-26: Drug Validation Screen Display - VistA Drug Not Validated / Not Auto Matched

If a VistA match was found for the drug, the screen looks similar to the below figure. The Status field has “NOT VALIDATED”, with VistA drug/SIG information displaying in the fields below.

```

PSO ERX DRUG VALIDATION          Nov 08, 2017@17:51:36          Page: 1 of 3
eRx Patient: ██████████
eRx Reference #: 10725
-----
eRx Drug: MELPHAALAN 2MG TAB
Qty: 60          Days Supply: 30          Date Written: NOV 08, 2017
Qty Qualifier: QUANTIFY SUFFICIENT
Drug Form: Orally Disintegrating Tablet Dosage Form
Strength: Microgram per Fifteen Milliliters
Potency Unit Code: International Unit
Refills: 0          Do not sub: NO PRODUCT SELECTION INDICATED
eRx Sig: TAKE ONE TABLET BY MOUTH 2 FOR 5 DAYS
eRx Notes: Authorizing refills. Patient must make appointment
-----
Status: NOT VALIDATED
(1) Vista Drug: MELPHALAN 2MG TAB
(2) *Dosage: 2
+-----+
+ Enter ?? for more actions
P Print          H Hold          UH Un Hold
E Edit          AV Accept Validation  RJ Reject
Select Item(s): Next Screen//

```

Figure 3-27: Drug Validation Screen Display - VistA Drug Matched / Not Validated

Edit Drug/SIG

1. To edit the drug/SIG information, use the <E> Edit action on the Drug Validation screen.
2. If the VistA drug/SIG information has been linked for the eRx, the edit drug/SIG sequence prompts the user to select a field or select All fields:
 - Select Item (s): Quit// E Edit
 - Which fields (s) would you like to edit? (1-10) or 'A' 11: A//
3. Under eRx Holding Queue >> Validate Drug/SIG screen >> Edit, if a drug is already matched in the hub, that drug is displayed at the 'select' prompt. The user is still allowed to change the drug by entering the drug name.
4. Under eRx Holding Queue >> Validate Drug/SIG screen >> Edit, if a drug is not matched in the hub, at the 'select' prompt, it is blank wherein the user can enter the drug name.
5. When a Yes/No confirmation is asked for the selected drug, if the user hits enter or selects 'No', the control comes out of Edit mode back to VD screen.

NOTE: The eRx Drug/SIG information from the external provider displays throughout the edit drug/SIG process as reference.

```

Drug Form: Orally Disintegrating Tablet Dosage FormStrength: Microgram per Fifteen Milliliters
Qty Qualifier: QUANTIFY SUFFICIENT Potency Unit Code: International Unit
DAW Code: NO PRODUCT SELECTION INDICATED
Qty: 60 Days Supply: 30 Refills: 0

Select DRUG GENERIC NAME: MELPHALAN 2MG TAB AN100

You have selected: MELPHALAN 2MG TAB
Would you like to use this drug/supply?
Enter Yes or No: YES

eRx Drug: MELPHAALAN 2MG TAB
eRx Sig: TAKE ONE TABLET BY MOUTH 2 FOR 5 DAYS
eRx Notes: Authorizing refills. Patient must make appointment

Available Dosage(s)
1. 2MG

Enter RETURN to continue or '^' to exit the list of dosages:

```

Figure 3-28: eRx Display During Edit Drug / SIG

6. Next, enter the Dosage. Either enter a free text dose or enter a question mark <?> to view a list of available dosages. The system prompts the user to confirm the selected dosage.
 - a. Enter the Verb, Route, Schedule, and Limited Duration (optional).
 - b. Patient Instructions are default/consistent instructions that come from the Orderable Item. VA Patient Instructions are auto populated when either a drug is automatched or manually matched or the drug's Pharmacy Order Item has an entry for those instructions. If it is blank, enter VA Patient Instructions. Or if it needs to be edited, use the 'Replace' function. Even abbreviated Patient Instructions from Medication Instruction files are allowed, which expand upon saving. This field holds the patient instructions for an eRx. This field is transferred to the Pending Queue upon acceptance of an eRx.
 - c. Provider Comments are additional free text comments that the provider may enter. The VA Provider Comments field contains the eRx Notes from the external provider and can be edited by entering <Replace>. Even abbreviated Provider Comments from Medication Instruction files are allowed, which expand upon saving. This field is transferred to the Pending Queue upon acceptance of an eRx.
 - d. Enter Patient Status and edit the Patient Status as required. (Note that this field will be auto-populated for MbM, with the text "CHOICE", whenever applicable).
 - e. Enter VistA Quantity, VistA Days Supply, and VistA Refills.
 - f. Enter Routing. Either <M> for Mail or <W> for Window.
 - g. The system displays the Default eRx Clinic setup by the site. If it is not configured, this field is blank. The user can select a clinic as required in either case.
 - h. Once all of the drug/SIG fields have been edited and the drug/SIG sequence is complete, the edited information displays on the Drug Validation screen.

- i. The next step is to accept the validation <AV>, which is described in the next section.
- j. If you have to edit after this you can pick the fields:
 - Select Item (s): Quit// E Edit
 - Which fields (s) would you like to edit? (1-10) or 'A' 11: A//

NOTE: If the Default eRx Clinic is changed from the one that's configured with the NPI Institution, of the receiving Pharmacy, the eRx may not show up in OERR when processed. Refer to the Inbound ePrescribing VistA Patch # PSO*7.0*467 Implementation Guide on the VA Documentation Library (VDL) for details on setting up the Default eRx Clinic for a site.

Additional Field-level Information:

- Potency Unit Code is displayed in the eRx Holding Queue >> Validate Drug/SIG screen >> Edit, along with the reference eRx information.
- eRx Quantity now displays up to 5 digits after the decimal in the eRx Holding Queue Summary Screen and VD >> Edit screen.
- VistA Quantity is displayed same as eRx Quantity if there are 2 digits after decimal places. If there are more than 2 digits after decimal places, VistA Quantity field is left blank so that the user can key in.
- eRx Days Supply now displays up to 999 in the eRx Holding Queue Summary Screen and VD >> Edit screen.
- VistA Days Supply is displayed same as eRx Days Supply if the value is under 366. If it is over 365, VistA Days Supply field is left blank so that the user can key in.
- eRx Refills now displays up to 99 in the eRx Holding Queue Summary Screen and VD >> Edit screen.
- VistA Refills is displayed same as eRx Refills if the value is under 12. If it is over 11, VistA Refills field is left blank so that the user can key in.
- Help text for VistA Quantity has been updated under eRx Holding Queue >> Validate Drug/SIG screen >> Edit.

Accept Drug/SIG Validation

Once the VistA Drug/SIG information has been edited and reviewed for accuracy, the next step is to accept the validation <AV> on the Drug Validation screen. The system prompts the user to confirm the validation. After entering <Y> Yes, a message displays that the drug validation has been updated.

```
-----Enter ?? for more actions-----
P Print                H Hold                UH Un Hold
E Edit                AV Accept Validation    RJ Reject
Select Item(s): Quit// AV Accept Validation

Would you like to mark this drug as VALIDATED?
Enter Yes or No: YES// YES
Validation Updated!!
Type <Enter> to continue or '^' to exit: █
```

Figure 3-29: Confirm Acceptance of Drug / SIG Validation

The Status changes to “VALIDATED” on the Drug Validation screen, along with the user who performed the validation and date/timestamp. “[v]” also displays to the right of the VistA Drug field on the Summary screen.

```
PSO ERX DRUG VALIDATION      Nov 08, 2017@17:56:14      Page: 1 of 3
eRx Patient: ██████████
eRx Reference #: 10725

eRx Drug: MELPHAALAN 2MG TAB
Qty: 60                      Days Supply: 30          Date Written: NOV 08, 2017

Qty Qualifier: QUANTIFY SUFFICIENT
Drug Form: Orally Disintegrating Tablet Dosage Form
Strength: Microgram per Fifteen Milliliters
Potency Unit Code: International Unit

Refills: 0                    Do not sub: NO PRODUCT SELECTION INDICATED
eRx Sig: TAKE ONE TABLET BY MOUTH 2 FOR 5 DAYS
eRx Notes: Authorizing refills. Patient must make appointment

-----
Status: VALIDATED (CHALLAGUNDLA,PRAVEEN - NOV 08, 2017@17:56:12)
(1) Vista Drug: MELPHALAN 2MG TAB
(2) *Dosage: 2
+-----
P Print                H Hold                UH Un Hold
E Edit                AV Accept Validation    RJ Reject
Select Item(s): Next Screen// █
```

Figure 3-30: Drug / SIG Validation Complete (Validate Drug / SIG Screen)

The modified VistA Drug/SIG information populates on the Drug/SIG Validation screen. Press <Enter> to display Pages 2 and 3 of the Drug/SIG Validation screen.

```

eRx Holding Queue Display      Nov 08, 2017@18:09:36      Page: 1 of 3
eRx Patient: [REDACTED]
eRx Reference #: 10723
-----
eRx Patient: [REDACTED]          DOB: [REDACTED]
Vista Patient[v]: [REDACTED]    DOB: [REDACTED]
eRx Provider: ATKINS,ANTHONY A   NPI: 2345698197
Vista Provider[v]: ATKINS,ANTHONY NPI: 2345698197
eRx Drug: ACYCLOVIR 800MG TAB
eRx Qty: 60          eRx Refills: 0   eRx Days Supply: 30   eRx Date: NOV 08, 2017
eRx Sig: TAKE ONE TABLET BY MOUTH 2 FOR 5 DAYS
Vista Drug[v]: ACYCLOVIR 800MG TAB
Vista Qty: 60          Vista Refills: 0       Vista Days Supply: 30
Vista Sig: TAKE ONE TABLET BY MOUTH TWICE A DAY FOR 4 DAYS
Pat Inst: TESTING
Hold Status:
+-----Enter ?? for more actions-----
VP VALIDATE PATIENT      VM VALIDATE PROVIDER      VD VALIDATE DRUG/SIG
P Print                  RJ Reject                  AC Accept eRx
H Hold                   UH Un Hold                 RM Remove eRx
Select Item(s): Next Screen//

```

Figure 3-31: Drug / SIG Validation Complete (Summary Screen)

Accepting eRx in the eRx Holding Queue

The following conditions must be met, before an eRx can be accepted and transmitted to the Pending Queue for further processing:

1. The eRx cannot be on Hold. If the eRx is on Hold, the eRx status on the Holding Queue List has one of the Hold Status codes, and the Hold Status, Hold Reason, and the user who placed the eRx on hold is displayed on the Summary screen.
2. The eRx cannot have a status of ‘Rejected’ **RJ**, ‘Removed’ **RM**, or ‘Processed’ **PR**.
3. All validation steps, for patient, provider, and drug/SIG must be completed, including the <AV> Accept Validation action on the validate screens. For additional information on the validation steps, please refer to the [Manual Validation](#) section of this guide.

If a user attempts to accept an eRx where one or more of the conditions have not been met, an error message displays indicating that the eRx cannot be processed and the reason why.

```

+-----Enter ?? for more actions-----
VP VALIDATE PATIENT      VM VALIDATE PROVIDER      VD VALIDATE DRUG/SIG
P Print                  RJ Reject                  AC Accept eRx
H Hold                   UH Un Hold                 RM Remove eRx
Select Item(s): Next Screen// AC   Accept eRx
Errors encountered during processing:
1.) Patient has not been manually validated.
2.) Provider has not been manually validated.
3.) Drug has not been manually validated.
Cannot process eRx.

```

Figure 3-32: Accept eRx - Sample Validation Errors

After all of the above pre-conditions have been met, to Accept an eRx <AC> from the Summary screen, complete the following steps.

From the Summary Screen, type <AC> Accept eRx.

```
+-----Enter ?? for more actions-----+
VP VALIDATE PATIENT          VM VALIDATE PROVIDER      VD VALIDATE DRUG/SIG
P  Print                    RJ Reject                AC Accept eRx
H  Hold                     UH Un Hold          RM Remove eRx
Select Item(s): Next Screen// AC  Accept eRx
```

Figure 3-33: Accept eRx

A message displays notifying the user that the eRx was sent to Pending Outpatient Orders for further processing.

```
Select Item(s): Next Screen// AC  Accept eRx
eRx #7205 sent to PENDING OUTPATIENT ORDERS!
Type <Enter> to continue or '^' to exit:
```

Figure 3-34: eRx Sent to Pending Outpatient Orders

The user can then go to Complete Orders from OERR or Patient Prescription Processing to view the eRx information. Refer to the [Complete Orders from OERR and Patient Prescription Processing](#) section.

Rejecting eRx in the eRx Holding Queue

Reject is used to remove the eRx from the eRx Holding Queue and send an NCPDP message back to the originating EHR system indicating that eRx has been rejected. Reject must be accompanied by a reject code/reason. To reject an eRx, complete the following steps:

1. From the Summary screen, type <RJ> Reject.
2. Enter <Y> Yes to confirm the reject.
3. Enter a reason for the rejection. The following reasons are available:
 - 203 PTT01 – Patient not eligible
 - 204 PTT02 – Cannot resolve patient
 - 205 PVD01 – Provider not eligible
 - 206 PVD02 – Cannot resolve provider
 - 207 DRU01 – Not eligible for refills
 - 208 DRU02 – Non-formulary drug
 - 209 DRU03 – Duplicate prescription found for this patient
 - 210 DRU04 – Invalid quantity

- 211 DRU05 – Duplicate therapeutic class
 - 212 DRU06 – Controlled substances are disallowed
 - 213 ERR01 – Multiple errors, please contact the pharmacy
 - 214 ERR02 – Incorrect pharmacy
 - 215 ERR03 – Issues with prescription, please contact the pharmacy
4. Type additional comments as to why the eRx is being rejected and press <Enter>. These comments are optional.

```
Select Item(s): Next Screen// RJ   Reject
Would you like to 'Reject' eRx #7484? Y// YES
Select REJECT reason code: 204   PTT02       Cannot resolve Patient
Additional Comments (Optional):

Rejection message sent.
Type <Enter> to continue or '^' to exit: █
```

Figure 3-35: Rejecting an eRx

Once the eRx is rejected, the details of the reject message will be available in the IEP Processing Hub as reference. Refer to the figure below.

Error - (Sent)	Status: OB_MSG_SEND_COMPLETED	Received Date: 11/08/2017
PHARMACY		
NCPDP ID:	11111114	
PRESCRIBER		
NPI/Clinic ID:	6666666666	
PRESCRIPTION		
Message ID:	10894.35788.162.3171108.165853	
Rel to Msg ID:	PRAVEEN3_11062017	
CODES and DESCRIPTION		
Code:	900	
Desc Code:		
Description:	PVD01-Provider not eligible	

Figure 3-36: Reject Message in Processing Hub

Printing in the eRx Holding Queue

From the Summary screen and from any of the validate screens, the <P> Print action is available to print the eRx.

1. Enter <P> Print.
2. Enter the Device (local or network printer) and press <Enter>.

The print display of the eRx, refer to the figure below, prints to the selected printer.

```

*****PHARMACY INFORMATION*****
DAYTON VAMC PHARMACY
Address: 4100 W. THIRD STREET
        ADDITIONAL PHARM ADDR W/ 35 MAX LEN
        MADISON, WISCONSIN 537050088
Tel:                                     NCPDP: 1111114
*****PRESCRIBER INFORMATION*****
First: ANTHONY
Mid: A
Last: ATKINS
Address: [REDACTED]
        Newton, INDIANA 23456
NPI: 2345698197      DEA: AT9012345      State Lic: ABC4567777
Tel:                                     Fax:
Supervisor:
Agent:
*****PATIENT INFORMATION*****
Last: [REDACTED]      First: [REDACTED]      Mid:
SSN: [REDACTED]      Sex: MALE
Address: [REDACTED]
        NEW PORT RICHEY, FLORIDA 34655
DOB: MAY 05, 1984      Home:
*****PRESCRIPTION INFORMATION*****
eRx Drug: ACYCLOVIR 800MG TAB
Qty: 60      Days Supply: 30      Date written: NOV 08, 2017
Qty Qualifier: QUANTIFY SU      Drug Form: Orally DisintegStrength: Microgram per F
Refills: 0
SIG: TAKE ONE TABLET BY MOUTH 2 FOR 5 DAYS

eRx Reference #: 10723      Message ID: Test2_11082017
Dispense Notes: NO PRODUCT SELECTION INDICATED
Comments: Authorizing refills. Patient must make appointment
*****END OF eRx*****

```

Figure 3-37: Print Display of eRx

Placing eRx's on Hold in the eRx Holding Queue

An eRx can be placed on hold for various reasons indicating that there is an issue with the eRx.

NOTE: If an eRx is placed on hold, the user can continue with all of the available validate actions; however, the eRx cannot be accepted if an eRx is on hold.

1. To place an eRx on hold, type <H> Hold from the Summary screen or any of the validate screens.
2. Enter a hold reason from the available reasons. The following reasons are available:

118	HPT	PATIENT NOT FOUND
119	HPD	PROVIDER NOT FOUND
120	HNF	NON-FORMULARY DRUG THAT NEEDS APPROVAL
121	HSO	INSUFFICIENT STOCK
122	HDI	DRUG-DRUG INTERACTION
123	HAD	ADVERSE DRUG INTERACTION
124	HBA	BAD ADDRESS
125	HPC	PROVIDER CONTACTED
126	HPA	PRIOR APPROVAL NEEDED
127	HOR	OTHER REASON
128	HPP	PATIENT CONTACTED
129	HPR	HOLD DUE TO PATIENT REQUEST
130	HQY	QUANTITY OR REFILL ISSUE
3. To view the available hold reasons, enter a double question mark <??> at the “Select HOLD reason code” prompt, refer to the figure below. The available hold reasons display.

```
-----Enter ?? for more actions-----
P Print                H Hold                UH Un Hold
E Edit                AV Accept Validation    RJ Reject
Select Item(s): Quit// H Hold
Select HOLD reason code: ??

Choose from:
118 HPT PATIENT NOT FOUND
119 HPD PROVIDER NOT FOUND
120 HNF NON-FORMULARY DRUG THAT NEEDS APPROVAL
121 HSO INSUFFICIENT STOCK
122 HDI DRUG-DRUG INTERACTION
123 HAD ADVERSE DRUG INTERACTION
124 HBA BAD ADDRESS
125 HPC PROVIDER CONTACTED
126 HPA PRIOR APPROVAL NEEDED
127 HOR OTHER REASON
128 HPP PATIENT CONTACTED
129 HPR HOLD DUE TO PATIENT REQUEST
130 HQY QUANTITY OR REFILL ISSUE

Select HOLD reason code: █
```

Figure 3-38: Hold eRx

4. Enter the reason code at the “Select HOLD Reason code:” prompt and press <Enter>.
5. A prompt displays asking for additional comments on the reason for the hold. These comments are optional. Either press <Enter> to complete the hold process or add comments and then press <Enter>.

```
Select HOLD reason code: HPT          PATIENT NOT FOUND
Additional Comments (Optional): RESEARCHING PATIENT INFORMATION
```

Figure 3-39: Select Hold Reason Code

The Hold Status, Hold Reason, and the user placing the eRx on hold display below the VistA Drug section on the Summary screen.

```
Hold Status: HPT - PATIENT NOT FOUND
Hold Reason: RESEARCHING PATIENT INFORMATION
Placed on hold by: TEST PHARMACIST, ERX
```

Figure 3-40: Hold Status and Reason

The hold status also displays in the “Status” column (STA) on the Holding Queue List screen.

PSO ERX HOLDING QUEUE		Nov 08, 2017@18:27:58		Page: 1 of 1	
Patient	DOB	Drug	Provider	STA	Rec Date
1. PATIENT, TEST		SILDENAFIL CITRATE 10	TEST PRESCR	I	10/24/17
2. ZZERYCTE FLORENCE		METHYLPREDN ACETATE 4	PROVIDER, ER	I	10/24/17
3. [REDACTED]	[REDACTED]	ASPIRIN 325MG TAB	BARHAN, MADH	I	11/1/17
4. [REDACTED]	[REDACTED]	METHYLPREDNISOLONE AC	PROVIDER, ER	N	11/8/17
5. [REDACTED]	[REDACTED]	METHYLPREDNISOLONE AC	PROVIDER, ER	N	11/8/17
6. [REDACTED]	[REDACTED]	CEFIXIME 200MG TAB	BARHAN, MADH	N	11/8/17
7. [REDACTED]	[REDACTED]	MELPHAALAN 2MG TAB	LEULU, LAURE	I	11/8/17
8. [REDACTED]	[REDACTED]	BENAZEPRIL HCL 20MG T	LEULU, LAURE	N	11/8/17
9. [REDACTED]	[REDACTED]	TRIFLUOPERAZINE 5MG T	LEULU, LAURE	N	11/8/17
10. [REDACTED]	[REDACTED]	RISEDRONATE NA 35MG T	LEULU, LAURE	N	11/8/17
11. [REDACTED]	[REDACTED]	ACETAZOLAMIDE 250MG T	LEULU, LAURE	N	11/8/17
12. [REDACTED]	[REDACTED]	CETIRIZINE HCL 10MG T	LEULU, LAURE	HPT	11/8/17
13. [REDACTED]	[REDACTED]	GAUZE PAD 2IN X 2IN S	ALBRECHT, AL	N	11/8/17
14. [REDACTED]	[REDACTED]	DIAPER ADULT MEDIUM	TILGH, JOHNI	N	11/8/17
15. [REDACTED]	[REDACTED]	DIAPER PROTECTIVE UND	TILGH, JOHNI	N	11/8/17

Enter ?? for more actions

SI Select Item
 SR Search Queue
 SO Sort Entries
 Select Action:Quit// █

Figure 3-41: Hold Status in Status Column

Un Hold eRx in the eRx Holding Queue

eRx_s may be removed from a hold by typing <UH> Un Hold. Users who see the Un Hold function in parentheses () are not able to remove an eRx from a hold.

```
VP VALIDATE PATIENT      VM VALIDATE PROVIDER      VD VALIDATE DRUG/SIG
P  Print                 RJ Reject                 AC Accept eRx
H  Hold                  UH Un Hold                RM Remove eRx
Select Item(s): Next Screen// UH Un Hold

eRx removed from hold status, and placed to 'In Progress'.
Type <Enter> to continue or '^' to exit:
```

Figure 3-42: Un Hold eRx

Removing eRx's in the eRx Holding Queue

An eRx can be removed from the Holding Queue without sending a message back to the originating external provider. Sample scenarios, include, but are not limited to, the patient requested that the eRx not be filled, or the user has been unable to contact the provider or patient for a significant amount of time.

To remove an eRx from the Holding Queue:

1. From the Summary screen, type <RM> Remove.
2. Enter a reason for the eRx removal. The following removal reasons are available:

216	REM01	Drug out of stock or on backorder and unavailable for processing
217	REM02	Patient was not able to pick up
218	REM03	Prescription canceled by Provider
219	REM04	Prescription processed manually
220	REM05	Provider will cancel this eRx and submit another
221	REM06	Unable to mail prescription and patient unable to pick up
222	REM07	Unable to contact patient
223	REM08	Unable to contact provider
224	REM91	Undefined system error
225	REM92	Other
3. Type additional comments as to why the eRx is being removed and press <Enter>. These comments are optional.

Once the eRx is removed, the status changes to “RM” and it no longer displays in the default Holding Queue list; however, the eRx can be accessed via the search action from the main Holding Queue List screen using one or more of the search criteria. Refer to [Searching eRx's](#).

VP VALIDATE PATIENT	VM VALIDATE PROVIDER	VD VALIDATE DRUG/SIG
P Print	RJ Reject	AC Accept eRx
H Hold	UH Un Hold	RM Remove eRx
Select Item(s): Next Screen// RM Remove eRx		
Would you like to 'Remove' eRx #1691? Y// YES		
Select REMOVAL reason code: 216 REM01 Drug out of stock or on backorder and unavailable for processing		
Additional Comments (Optional):		

Figure 3-43: Removing an eRx

NOTE: If the Remove eRx function is in parentheses (), the user will not be able to remove an eRx. If the action is still attempted, the user receives a message that the action is not available.

Searching and Sorting in the eR_x Holding Queue

Users can search and sort eR_xs in the Holding Queue. Searching and sorting eR_xs is described in the following sections.

Searching eR_xs

Searching and filtering of eR_xs is available by typing <SR> Search Queue at the “Select Action” prompt. The Search Queue screen displays. Users can search using one or more of the following search criteria:

1. PATIENT NAME
2. DATE OF BIRTH
3. RECEIVED DATE RANGE
4. PROVIDER NAME
5. ERX STATUS
6. DRUG NAME

```
SI   Select Item
SR   Search Queue
SO   Sort Entries
Select Action:Next Screen// SR   Search Queue

1.) PATIENT NAME
2.) DATE OF BIRTH
3.) RECEIVED DATE RANGE
4.) PROVIDER NAME
5.) ERX STATUS
6.) DRUG NAME
```

Figure 3-44: Search Queue Action

The default search displays all eR_xs except **RM** Removed, **RJ** Rejected, or **PR** Processed items (unless the user searches by ERX STATUS and specifically selects one of these statuses. The display contains all eR_xs satisfying the search criteria. The list is refreshed depending on the action performed. After an action is performed, the user can return to the original filtered list.

Search eR_x – Patient Name

Users can search by patient name. A search initiated with a partial patient name may return multiple patient names, from which one patient can be selected. Selecting a patient displays the eR_xs for that patient.

To search by patient name:

1. From the eR_x Holding Queue List screen, type <SR> Search Queue.

- From the Search Queue, type <1> or PATIENT NAME.

```
Select one of the following:
  1 PATIENT NAME
  2 DATE OF BIRTH
  3 RECEIVED DATE RANGE
  4 PROVIDER NAME
  5 ERX STATUS
  6 DRUG NAME
Enter response: 1 PATIENT NAME
```

Figure 3-45: Search Criteria - Patient Name

- Type the full or partial name of the patient press <Enter>. If multiple patients exist for the search criteria entered, select the correct patient from the list provided.

```
Select ERX EXTERNAL PATIENT NAME: PATIENT, TEST
  1 PATIENT,TEST
  2 PATIENT,TEST
CHOOSE 1-2: █
```

Figure 3-46: Patient Name Search

- A message displays indicating that the user can enter additional search criteria or press <Enter> to continue with the current search.
- The search results display.
- To execute another search, enter ^ or Quit to exit the current search and return to the original Holding Queue list. The SR Search Queue action is in parentheses, indicating that the user must exit the current search to execute a new search.

PSO ERX HOLDING QUEUE		Nov 08, 2017@18:33:10		Page: 1 of 1	
Patient	DOB	Drug	Provider	STA	Rec Date
1. INBERXSRTTESTPATA, FN	[REDACTED]	ASPIRIN 325MG TAB	BARHAN, MADH I		11/1/17
2. INBERXSRTTESTPATA, FN	[REDACTED]	CEFIXIME 200MG TAB	BARHAN, MADH N		11/8/17

Enter ?? for more actions

SI Select Item
SR (Search Queue)
SO Sort Entries

Select Action:Quit//

Figure 3-47: Search eRx by Patient Name Results

Search eRx – Date of Birth

To search by patient's date of birth:

1. From the eRx Holding Queue List screen, type <SR> Search Queue.
2. From the Search Queue Type <2> or DATE OF BIRTH.
3. Enter the date of birth and press <Enter>.

A message displays indicating that the user can enter additional search criteria or press <Enter> to continue with the current search.

```
Select one of the following search criteria:
Enter response: 2 DATE OF BIRTH
Enter the Date of Birth (DOB):
```

Figure 3-48: Search Criteria - Date of Birth

The search results in the following display:

PSO ERX HOLDING QUEUE		Nov 08, 2017@18:35:44		Page: 1 of 1	
Patient	DOB	Drug	Provider	STA	Rec Date
1.		ACYCLOVIR 800MG TAB	ATKINS,ANTH RJ		10/5/17
2.		ACYCLOVIR 800MG TAB	ATKINS,ANTH RM		10/16/17
3.		AMLODIPINE 5 MG ORAL	ATKINS,ANTH PR		10/17/17
4.		ACYCLOVIR 800MG TAB	ATKINS,ANTH PR		11/8/17
5.		MELPHAALAN 2MG TAB	LEULU,LAURE I		11/8/17
6.		BENZAEPRIIL HCL 20MG T	LEULU,LAURE N		11/8/17

Enter ?? for more actions

SI Select Item
SR (Search Queue)
SO Sort Entries
Select Action:Quit//

Figure 3-49: Search eRx by Date of Birth Results

Search eRx – Received Date Range

To search for an eRx by a received date range:

1. From the eRx Holding Queue List screen, type <SR> Search Queue.
2. Type <3> or RECEIVED DATE RANGE.

```

Select one of the following:
3 RECEIVED DATE RANGE
4 PROVIDER NAME
5 ERX STATUS
6 DRUG NAME

Enter response: 3 RECEIVED DATE RANGE

```

Figure 3-50: Search Criteria - Received Date Range

2. Enter the beginning date and press <Enter>.
3. Enter the ending date and press <Enter>.
4. A message displays indicating that the user can enter additional search criteria or press <Enter> to continue with the current search.

```

Select one of the following search criteria:
Enter response: 3 RECEIVED DATE RANGE
Enter the beginning date: 11/08/2017
Enter the ending date: T//

```

Figure 3-51: Enter Beginning and Ending Date

The search results display.

Patient		DOB	Drug	Provider	STA	Rec Date
1.			METHYLPREDNISOLONE AC	PROVIDERQQQ	PR	11/8/17
2.			METHYLPREDNISOLONE AC	PROVIDER,ER	N	11/8/17
3.			METHYLPREDNISOLONE AC	PROVIDER,ER	N	11/8/17
4.			CEFIXIME 200MG TAB	BARHAN,MADH	N	11/8/17
5.			ACYCLOVIR 800MG TAB	ATKINS,ANTH	PR	11/8/17
6.			MELPHAALAN 2MG TAB	LEULU,LAURE	I	11/8/17
7.			BENAZEPRIL HCL 20MG T	LEULU,LAURE	N	11/8/17
8.			TRIFLUOPERAZINE 5MG T	LEULU,LAURE	N	11/8/17
9.			RISEDRONATE NA 35MG T	LEULU,LAURE	N	11/8/17
10.			ACETAZOLAMIDE 250MG T	LEULU,LAURE	N	11/8/17
11.			CETIRIZINE HCL 10MG T	LEULU,LAURE	HPT	11/8/17
12.			GAUZE PAD 2IN X 2IN S	ALBRECHT,AL	N	11/8/17
13.			DIAPER ADULT MEDIUM	TILGH,JOHNI	N	11/8/17
14.			DIAPER PROTECTIVE UND	TILGH,JOHNI	N	11/8/17

Enter ?? for more actions

SI Select Item
SR (Search Queue)
SO Sort Entries
Select Action:Quit// █

Figure 3-52: Search eRx by Received Date Range

Search eRx – Provider Name

To search for an eRx by a provider:

1. From the eRx Holding Queue List screen, type <SR> Search Queue.
2. Type <4> or PROVIDER NAME.

```

Select one of the following:

1      PATIENT NAME
2      DATE OF BIRTH
3      RECEIVED DATE RANGE
4      PROVIDER NAME
5      ERX STATUS
6      DRUG NAME

Enter response: 4 PROVIDER NAME

```

Figure 3-53: Search Criteria - Provider Name

3. Type the provider's name and press <Enter>.

```

Select one of the following search criteria:

Enter response: 4 PROVIDER NAME
Select PROVIDER: LEULU,LAUREN A      2445698197      CT9012345

```

Figure 3-54: Enter Provider Name

The search results in the following display:

PSO ERX HOLDING QUEUE		Nov 08, 2017@18:41:03		Page: 1 of 1	
Patient	DOB	Drug	Provider	STA	Rec Date
1.		MELPHAALAN 2MG TAB	LEULU,LAURE	I	11/8/17
2.		BENAZEPRIL HCL 20MG T	LEULU,LAURE	N	11/8/17
3.		TRIFLUOPERAZINE 5MG T	LEULU,LAURE	N	11/8/17
4.		RISEDRONATE NA 35MG T	LEULU,LAURE	N	11/8/17
5.		ACETAZOLAMIDE 250MG T	LEULU,LAURE	N	11/8/17
6.		CETIRIZINE HCL 10MG T	LEULU,LAURE	HPT	11/8/17

Enter ?? for more actions

```

SI Select Item
SR (Search Queue)
SO Sort Entries
Select Action:Quit//

```

Figure 3-55: Search eRx by Provider

Search eRx – ERX Status

To search for an eRx by Status:

1. From the eRx Holding Queue List screen, type <SR> Search Queue.
2. Type <5> or ERX STATUS.
3. Enter the eRx status and press <Enter>.

```
Enter response: 5 ERX STATUS
Select eRx Status: RJ REJECTED
```

Figure 3-56: Search Criteria - eRx Status

The search results display.

PSO ERX HOLDING QUEUE		Nov 08, 2017@18:44:23		Page: 7 of 8		
PSO ERX HOLDING QUEUE						
+	Patient	DOB	Drug	Provider	STA	Rec Date
104.		I	METHYLPREDNISOLONE AC	PROVIDER,ER	RJ	10/23/17
105.		I	METHYLPREDNISOLONE AC	PROVIDER,ER	RJ	10/23/17
106.			METHYLPREDNISOLONE AC	PROVIDER,ER	RJ	10/23/17
107.		R	METHYLPREDNISOLONE AC	PROVIDER,ER	RJ	10/23/17
108.			METHYLPREDNISOLONE AC	PROVIDER,ER	RJ	10/23/17
109.			METHYLPREDNISOLONE AC	PROVIDER,ER	RJ	10/23/17
110.			METHYLPREDNISOLONE AC	PROVIDER,ER	RJ	10/23/17
111.			METHYLPREDN ACETATE 4	PROVIDER,ER	RJ	10/23/17
112.			METHYLPREDNISOLONE AC	PROVIDER,ER	RJ	11/2/17
113.			METHYLPREDNISOLONE AC	PROVIDER,ER	RJ	11/2/17
114.		Q	METHYLPREDNISOLONE AC	PROVIDER,ER	RJ	11/6/17
115.		Q	METHYLPREDNISOLONE AC	PROVIDERQQQ	RJ	11/6/17
116.		Q	METHYLPREDNISOLONE AC	PROVIDERQQQ	RJ	11/6/17
117.		Q	METHYLPREDNISOLONE AC	PROVIDERQQQ	RJ	11/7/17
118.			ACETAMINOPHEN 325MG T	BARHAN,MADH	RJ	11/7/17

Enter ?? for more actions

SI Select Item
SR (Search Queue)
SO Sort Entries
Select Action:Quit//

Figure 3-57: Search by eRx Status

For more information on the available statuses in the Holding Queue, refer to [Appendix A Holding Queue Status Codes & Descriptions](#).

Search eRx – Drug Name

To search for an eRx by Drug Name:

1. From the eRx Holding Queue List screen, type <SR> Search Queue.
2. Type <6> or DRUG NAME.
3. Type the name or partial name of the incoming eRx drug and press <Enter>.

```
Select one of the following search criteria:  
Enter response: 6 DRUG NAME  
Enter the name or partial name of the incoming eRx drug: ACYCLOVIR
```

Figure 3-58: Search Criteria - Drug Name

The search results the following display:

Patient	DOB	Drug	Provider	STA	Rec Date
[Redacted]	[Redacted]	ACYCLOVIR 800MG TAB	ATKINS, ANTH	RJ	10/5/17
[Redacted]	[Redacted]	ACYCLOVIR 800MG TAB	ATKINS, ANTH	RM	10/16/17
[Redacted]	[Redacted]	ACYCLOVIR 800MG TAB	ATKINS, ANTH	PR	11/8/17

Enter ?? for more actions

SI Select Item
SR (Search Queue)
SO Sort Entries
Select Action:Quit//

Figure 3-59: Search eRx by Drug Name

Sorting eRx's

VA users can sort eRx's in the Holding Queue List. Sort parameters are retained at the user level when reentering the original list during the same session (i.e., when performing an action on an eRx and then reentering the eRx list). The default sort order of the Holding Queue list is the following:

1. Date Received - Oldest date to Newest date
2. Secondary sort by PATIENT NAME

Additional sorting of eRx's is available by typing <SO> Sort Entries.

PSO ERX HOLDING QUEUE		Nov 08, 2017@18:47:40		Page: 1 of 1	
Patient	DOB	Drug	Provider	STA	Rec Date
1.		SILDENAFIL CITRATE 10	TEST PRESCR I		10/24/17
2.		METHYLPREDN ACETATE 4	PROVIDER,ER I		10/24/17
3.		ASPIRIN 325MG TAB	BARHAN,MADH I		11/1/17
4.		METHYLPREDNISOLONE AC	PROVIDER,ER N		11/8/17
5.		METHYLPREDNISOLONE AC	PROVIDER,ER N		11/8/17
6.		CEFIXIME 200MG TAB	BARHAN,MADH N		11/8/17
7.		MELPHAALAN 2MG TAB	LEULU,LAURE I		11/8/17
8.		BENAZEPRIL HCL 20MG T	LEULU,LAURE N		11/8/17
9.		TRIFLUOPERAZINE 5MG T	LEULU,LAURE N		11/8/17
10.		RISEDRONATE NA 35MG T	LEULU,LAURE N		11/8/17
11.		ACETAZOLAMIDE 250MG T	LEULU,LAURE N		11/8/17
12.		CETIRIZINE HCL 10MG T	LEULU,LAURE HPT		11/8/17
13.		GAUZE PAD 2IN X 2IN S	ALBRECHT,AL N		11/8/17
14.		DIAPER ADULT MEDIUM	TILGH,JOHNI N		11/8/17
15.		DIAPER PROTECTIVE UND	TILGH,JOHNI N		11/8/17

Enter ?? for more actions

SI Select Item
 SR Search Queue
 SO Sort Entries
 Select Action:Quit//

Figure 3-60: Sort Entries Action

eRx's can be sorted by only one criterion at a time. The sort criteria include:

- **Patient Name:** Sorted by Patient in ascending order (A-Z), and within Patient by Received Date with most recent first, and then by Provider in ascending order (A-Z)
- **Date of Birth:** By DOB, newest Received Date first, Patient Name ascending
- **Received Date Range:** Sorted by Received Date with most recent first and within Received Date by Patient in ascending order (A-Z), and then by Provider in ascending order (A-Z)
- **Provider Name:** Sorted by Provider in ascending order (A-Z), and within Provider by Received Date with oldest first, and then by Patient in ascending order (A-Z)
- **eRx Status:** Patient Name ascending, newest Received Date first
- **Drug Name:** Patient Name ascending, newest Received Date first

Sort eRx – Patient Name

To sort by patient:

1. From the eRx Holding Queue List screen, type <SO> Sort Entries.
2. Type <1> or PATIENT NAME.

```
-----Enter ?? for more actions-----
SI  Select Item
SR  Search Queue
SO  Sort Entries
Select Action:Quit// SO  Sort Entries

Select one of the following:

1  PATIENT NAME
2  DATE OF BIRTH
3  RECEIVED DATE RANGE
4  PROVIDER NAME
5  ERX STATUS
6  DRUG NAME

Enter response: 1
```

Figure 3-61: Sort by Patient Name

3. The sorted entries display Sorted by Patient in ascending order (A-Z), and within Patient by Received Date Range with most recent first, and then by Provider in ascending order (A-Z).

Sort eRx – Date of Birth

To sort by Date of Birth:

1. From the eRx Holding Queue List screen, type <SO> Sort Entries.
2. Type <2> or DATE OF BIRTH.
3. The entries display by DOB, newest Received Date first, Patient Name ascending.

Sort eRx – Received Date Range

To sort eRx's by received date (most recent date displays at top of sort results):

1. From the eRx Holding Queue List screen, type <SO> Sort Entries.
2. Type <3> or RECEIVED DATE RANGE.

```
SI Select Item
SR Search Queue
SO Sort Entries
Select Action:Next Screen// so Sort Entries

Select one of the following sort criteria:

1.) PATIENT NAME
2.) DATE OF BIRTH
3.) RECEIVED DATE RANGE
4.) PROVIDER NAME
5.) ERX STATUS
6.) DRUG NAME
```

Figure 3-62: Sort by Received Date Range

3. The entries sort by Received Date with most recent first and within Received Date by Patient in ascending order (A-Z), and then by Provider in ascending order (A-Z).

Sort eRx – Provider Name

To sort eRx's by provider name:

1. From the eRx Holding Queue List screen, type <SO> Sort Entries.
2. Type <4> or PROVIDER NAME.

```
SI Select Item
SR Search Queue
SO Sort Entries
Select Action:Next Screen// SO Sort Entries

Select one of the following sort criteria:

1.) PATIENT NAME
2.) DATE OF BIRTH
3.) RECEIVED DATE RANGE
4.) PROVIDER NAME
5.) ERX STATUS
6.) DRUG NAME
```

Figure 3-63: Sort Criteria - Sort by Provider

3. The entries sort by Provider in ascending order (A-Z), and within Provider by Received Date with oldest first, and then by Patient in ascending order (A-Z).

Sort eRx – eRx Status

To sort eRx's by eRx Status:

1. From the eRx Holding Queue List screen, type <SO> Sort Entries.
2. Type <5> or ERX STATUS.
3. The entries sort by Patient Name ascending, newest Received Date first.

Sort eRx – Drug Name

To sort eRx's by Drug Name:

1. From the eRx Holding Queue List screen, type <SO> Sort Entries.
2. Type <6> or DRUG NAME.
3. The entries sort by Patient Name ascending, newest Received Date first.

Complete Orders from OERR and Patient Prescription Processing

Following all of the validation steps for patient, provider, and drug/SIG, and after the eRx has been accepted, the eRx advances to Pending Outpatient Orders file for further processing. The eRx is further finished using either Complete Orders from OERR or Patient Prescription Processing. The eRx information displays at the top of the screen under the Secondary header, as shown in the figure below in both Complete Orders from OERR and Patient Prescription Processing. The hidden Option EP is provided in Outpatient to print the eRx (see figure below).

```
Provider Comments: good comments
Instructions:
      SIG: INSTILL 2 DROPS IN BOTH EYES TWICE A DAY
(5) Patient Status: SC
(6) Issue Date: MAR 1,2017      (7) Fill Date: OCT 19,2017
+-----Enter ?? for more actions-----
BY Bypass          DC Discontinue      FL Flag/Unflag
ED Edit           FN Finish
Select Item(s): Next Screen// ??

BY Bypass          DC Discontinue      FL Flag/Unflag
ED Edit           FN Finish

The following actions are also available:
EX Exit (OP)       < Shift View to Left  PS Print Screen
PI Patient Information > Shift View to Right PT Print List
DIN Drug Rests/Guide (OP) ADPL Auto Display(On/Off) QT Quit
EP Print eRx      DN Down a Line      RD Re Display Screen
IN Intervention Menu FS First Screen      SL Search List
+ Next Screen     GO Go to Page       UP Up a Line
- Previous Screen LS Last Screen

Type <Enter> to continue or '^' to exit:
```

Figure 3-64: Hidden Option EP / Print Display of eRx

The eRx information can be edited as per current functionality and either finished to process further for dispensing or discontinued as needed (such as in case of duplicate orders since it is not filtered in the eRx Holding Queue. (See figure below).

```

Pending OP Orders (ROUTINE)  Nov 08, 2017@18:18:52  Page: 1 of 5
PID: [REDACTED]  <NO ALLERGY ASSESSMENT>
DOB: [REDACTED]  Ht(cm): ( )
Wt(kg): ( )

eRx Accepted By: CHALLAGUNDLA,PRAVEEN (NOV 08, 2017@18:11:26)
eRx Patient: [REDACTED]  SSN: [REDACTED]
DOB: [REDACTED]

eRx Provider: ATKINS,ANTHONY A  DEA: AT9012345
NPI: 2345698197

Address: 1234 Florida stBldg#500 Newton,INDIANA 23456

eRx Drug: ACYCLOVIR 800MG TAB
Qty: 60  Days Supply: 30  Refills: 0
eRx Sig: TAKE ONE TABLET BY MOUTH 2 FOR 5 DAYS
eRx Notes: Authorizing refills. Patient must make appointment

+ Enter ?? for more actions
BY Bypass  DC Discontinue  FL Flag/Unflag
ED Edit  FN Finish
Select Item(s): Next Screen//

```

Figure 3-65: eRx Display in Pending Queue - Page 1

Please refer to the user manuals available on the VA Documentation Library (VDL) for information on Complete Orders from OERR and Patient Prescription Processing.

Press <Enter> to view Pages 2 and 5 of the order in the Pending Queue.

```

Pending OP Orders (ROUTINE)  Nov 08, 2017@18:20:27  Page: 2 of 5
PID: [REDACTED]  <NO ALLERGY ASSESSMENT>
DOB: [REDACTED]  Ht(cm): ( )
Wt(kg): ( )

+
Drug Form: Orally Disintegrating Tablet Dosage Form
Strength: Microgram per Fifteen Milliliters
Qty Qualifier: QUANTIFY SUFFICIENT
Potency Unit Code: International Unit

DAW Code: NO PRODUCT SELECTION INDICATED

Diagnosis Sequence: 1
Primary DX Qualifier: ICD-10-CM
Primary Dx Value: PRIMARYDIAGCODE.1

Secondary DX Qualifier: ICD-9-CM
Secondary Dx Value: SECOND.DIAGCODE.1
Diagnosis Sequence: 2

+ Enter ?? for more actions
BY Bypass  DC Discontinue  FL Flag/Unflag
ED Edit  FN Finish
Select Item(s): Next Screen//

```

Figure 3-66: eRx Order in Pending Queue – Page 2

Pending OP Orders (ROUTINE)		Nov 08, 2017@18:21:58	Page: 3 of 5
PID: [REDACTED]		<NO ALLERGY ASSESSMENT>	
DOB: [REDACTED]		Ht(cm): _____ (____)	
		Wt(kg): _____ (____)	
+ Primary DX Qualifier: ICD-9-CM			
Primary Dx Value: PRIMARYDIAGCODE.2			
Secondary DX Qualifier: ICD-10-CM			
Secondary Dx Value: SECOND.DIAGCODE.2			

*(1) Orderable Item: ACYCLOVIR TAB			
(2) CMOP Drug: ACYCLOVIR 800MG TAB			
(3) *Dosage: 800 (MG)			
Verb: TAKE			
Dispense Units: 1			
Noun: TABLET			
*Route: MOUTH			
*Schedule: BID			
+ Enter ?? for more actions			
BY Bypass	DC Discontinue	FL Flag/Unflag	
ED Edit	FN Finish		
Select Item(s): Next Screen// <input type="checkbox"/>			

Figure 3-67: eRx Order in Pending Queue - Page 3

Pending OP Orders (ROUTINE)		Nov 08, 2017@18:23:18	Page: 4 of 5
PID: [REDACTED]		<NO ALLERGY ASSESSMENT>	
DOB: [REDACTED]		Ht(cm): _____ (____)	
		Wt(kg): _____ (____)	
+ *Duration: 4D (DAYS)			
(4) Pat Instruct: TESTING			
Provider Comments: AUTHORIZING REFILLS. PATIENT MUST MAKE APPOINTMENT			
Instructions: TAKE 1 TABLET BID 4D			
SIG: TAKE ONE TABLET BY MOUTH TWICE A DAY FOR 4 DAYS TESTING			
(5) Patient Status: SC			
(6) Issue Date: NOV 8,2017		(7) Fill Date: NOV 8,2017	
(8) Days Supply: 30		(9) QTY (TAB): 60	
Provider ordered 0 refills			
(10) # of Refills: 0		(11) Routing: MAIL	
(12) Clinic: ANGIO			
(13) Provider: ATKINS,ANTHONY			
(14) Copies: 1			
(15) Remarks:			
+ Enter ?? for more actions			
BY Bypass	DC Discontinue	FL Flag/Unflag	
ED Edit	FN Finish		
Select Item(s): Next Screen//			

Figure 3-68: eRx Order in Pending Queue - Page 4

```

Pending OP Orders (ROUTINE) Nov 08, 2017@18:24:59 Page: 5 of 5
PID: [REDACTED] <NO ALLERGY ASSESSMENT>
DOB: [REDACTED] Ht(cm): ( )
Wt(kg): ( )
+
Entry By: ATKINS,ANTHONY Entry Date: 11/08/17

Enter ?? for more actions
BY Bypass DC Discontinue FL Flag/Unflag
ED Edit FN Finish
Select Item(s): Quit// █

```

Figure 3-69: eRx Order in Pending Queue - Page 5

NOTE: The issue date is the same as Effective Date if sent by the Provider on the eRx, if not, it is the same as the Written Date as sent on the eRx.

Help Desk

For issues related to the VistA OP eRx Holding Queue that cannot be resolved by this manual or the site administrator, please contact the National Service Desk at 855-NSD-HELP (673-4357) and reference “Inbound eRx”.

Appendix A. Holding Queue Status Codes & Descriptions

Table 7: Holding Queue Status Codes & Descriptions

Status Type	VistA IEN Number	Status Code	Description
New		N	Status of the eR _x when it first arrives in the Holding Queue and has not been acted upon in anyway.
In Process		I	Status of the eR _x when a user has taken an action on the eR _x in the Holding Queue, including via the automatic patient or provider validation process.
Hold			Refer to the various hold statuses and descriptions below.
	118	HPT	PATIENT NOT FOUND
	119	HPD	PROVIDER NOT FOUND
	120	HNF	NON-FORMULARY DRUG THAT NEEDS APPROVAL
	121	HSO	INSUFFICIENT STOCK
	122	HDI	DRUG-DRUG INTERACTION
	123	HAD	ADVERSE DRUG INTERACTION
	124	HBA	BAD ADDRESS
	125	HPC	PROVIDER CONTACTED
	126	HPA	PRIOR APPROVAL NEEDED
	127	HOR	OTHER REASON
	128	HPP	PATIENT CONTACTED
	129	HPR	HOLD DUE TO PATIENT REQUEST
	130	HQY	QUANTITY OR REFILL ISSUE
Reject		RJ	Status of the eR _x when it has been rejected by a user. A message is sent back to the external provider indicating the eR _x was rejected and the reason for rejection. Refer to the various reject reasons below.
	203	PTT01	Patient not eligible

Status Type	VistA IEN Number	Status Code	Description
	204	PTT02	Cannot resolve patient
	205	PVD01	Provider not eligible
	206	PVD02	Cannot resolve provider
	207	DRU01	Not eligible for refills
	208	DRU02	Non-formulary drug
	209	DRU03	Duplicate prescription found for this patient
	210	DRU04	Invalid quantity
	211	DRU05	Duplicate therapeutic class
	212	DRU06	Controlled substances are disallowed
	213	ERR01	Multiple errors, please contact the pharmacy
	214	ERR02	Incorrect pharmacy
	215	ERR03	Issues with prescription, please contact the pharmacy
Remove		RM	Status of the eRx when it has been removed by a user. Note that a message is NOT sent back to the external provider when an eRx is removed. Refer to the various remove reasons below.
	216	REM01	Drug out of stock or on backorder and unavailable for processing
	217	REM02	Patient was not able to pick up
	218	REM03	Prescription canceled by Provider
	219	REM04	Prescription processed manually
	220	REM05	Provider will cancel this eRx and submit another
	221	REM06	Unable to mail prescription and patient unable to pick up
	222	REM07	Unable to contact patient
	223	REM08	Unable to contact provider

Status Type	VistA IEN Number	Status Code	Description
	224	REM91	Undefined system error

Appendix B. NCPDP Error Codes

This appendix outlines common NCPD error codes and their descriptions, which will be visible in the Detail View of a message in the IEP Web-based application.

Table 8: NCPDP Error Codes

Element Name	M/O	Datatype	Possible Values	Description
Code	M	String	600 601 602 900	600 Communication problem - try again later 601 Receiver unable to process 602 Receiver System Error 900 Transaction rejected
Description Code	O	String	001 002 003...	001 Sender ID not on file. 002 Receiver ID not on file. 003 Invalid password for sender. 004 Invalid password for receiver 005 No password on file for sender. 006 No password on file for receiver. 007 Internal processing error has occurred. 008 Request timed out before response could be received. 009 Required segment UIB is missing. 010 Required segment UIH is missing. 011 Required segment UIT is missing. 012 Required segment UIZ is missing. 013 Unknown segment has been encountered. etc.
Description	O	an (70)	Free text	