



BLIND REHABILITATION TECHNICAL MANUAL/SECURITY GUIDE



Version 5.0.29
August 2011

Department of Veterans Affairs
VistA Health System Design & Development

Revision History

<i>Date</i>	<i>Description</i>	<i>Author</i>
08/26/2005	Draft I	Pete Cartwright/Bud Gunn, PM
01/15/2006	Draft II	Pete Cartwright/Bud Gunn, PM
04/20/2006	Draft III	Pete Cartwright/Carl DeMoss/Rich Fischer, PM
05/25/2006	EVS Requested Revisions	Pete Cartwright/Carl DeMoss/Rich Fischer, PM
11/13/2006	Updates for version 5.0.27.5	Pete Cartwright/Barbara Lang, PM
12/06/2006	Updates for version 5.0.27.6	Pete Cartwright/Barbara Lang, PM
03/07/2007	<p>The following changes have occurred since the 5.0.26.8 version of this document:</p> <p>Page 4:</p> <ul style="list-style-type: none"> • Changed version number of Blind Rehabilitation from 5.0.26.8 to 5.0.27.6 • Changed version number of VistALink from 1.5.0.026 to 1.5.1.002 • Changed version number of Person Service Lookup from 4.0.4.3 to 4.0.4.4 • Changed version number of Standard Data Service API from 7.0 to 10.0 • Changed version number of Standard Data Service Database from 9.9 to 10.0 <p>Page 16:</p> <ul style="list-style-type: none"> • Changed version number of Blind Rehabilitation from 5.0.26.8 to 5.0.27.6 <p>Page 17:</p> <ul style="list-style-type: none"> • Changed version number of Person Service Lookup from 4.0.4.3 to 4.0.4.4 • Changed version number of Standard Data Services from 7.0 to 10.0 in two places • Removed vljConnector-1.5.0.026.jar, vljFoundationsLib-1.5.0.026.jar and vljSecurity-1.5.0.026.jar libraries <p>Page 24:</p> <ul style="list-style-type: none"> • Changed the description for the Crystal Enterprise v10 application to read "...publish and execute developed reports." instead of "...publish and test developed reports." <p>Page 26:</p> <ul style="list-style-type: none"> • Changed version number of Standard Data Service API from 7.0 to 10.0 • Changed version number of Standard Data Service Database from 9.9 to 10.0 • Changed version number of Person Service Lookup from 4.0.4.3 to 4.0.4.4 	Mike Nelis/Joe Niksich, PM

<i>Date</i>	<i>Description</i>	<i>Author</i>
08/23/2010	<p>The following changes have occurred for the version 5.0.29.4</p> <p>Page 4:</p> <ul style="list-style-type: none"> • Changed version number of Blind Rehabilitation from 5.0.27.6 to 5.0.29.4 • Changed version number of VistaLink from 1.5.0.026 to 1.5.2.004 • Changed version number of Kaajee 1.0.0.019 to 1.0.1.003 • Changed version number of Standard Data Service Database from 10.0 to 18.0 <p>Page 16:</p> <ul style="list-style-type: none"> • Changed version number of Blind Rehabilitation from 5.0.27.6 to 5.0.29.4 <p>Page 17:</p> <ul style="list-style-type: none"> • Changed version number of Standard Data Services Jars from 10.0 to 18.0 in two places <p>Page 26:</p> <ul style="list-style-type: none"> • Changed version number of Standard Data Service Database from 10.0 to 18.0 	Venkata Thippisetty/Kerry Zallar

Table of Contents

Introduction.....	1
Benefits	2
Enhanced Technology.....	2
VistA Software Requirements	3
HealthVet-VistA Software Requirements.....	4
Orientation	4
Recommended Users	4
Related Manuals.....	4
Documentation Retrieval	5
VistA Intranet.....	5
Implementation and Maintenance.....	5
BR Production Centralized Server Deployment	6
BR Sample Configuration.....	7
VistA Files	8
Routines	8
Security Keys.....	8
Exported VistA Options.....	9
Parameter Definition.....	10
Remote Procedure.....	10
Required Builds	10
External Interfaces	11
Database Integration Agreements (DBIAs).....	12
Software Product Security	13
Security Management	13
Strategic Initiatives Overview.....	14
Application Security	14
Audit Trail.....	14
Remote Systems.....	14
Archiving/Purging.....	14
Contingency Planning.....	14
Electronic Signatures	15
Security Keys.....	15
File Security	15
Reference	15
Official Policies	15
Blind Rehabilitation Application	16
Enterprise Archive	16
Application.xml	16
Weblogic-application.xml.....	16
APP-INF Directory	16
Web Archive File.....	18
Directory Contents	18
Web Archive web.xml File.....	19
Web Archive Weblogic.xml File	19
Struts Config Files	19
EJB Archive File.....	20
Application Property Files	21
Other Configuration Files	21

Exceptions.....	22
Service Imports	22
Java Enterprise Developer Workstation.....	24
Development Platform	24
Development Projects	25
Development Tools	25
ANT	25
Log4j.....	25
Chainsaw.....	25
Libraries	25
HealtheVet Services.....	25
SDS	26
VLJ.....	26
KAAJEE	26
PSL.....	26
PSC (formerly PSD)	26
Business Rule Implementation	27
Web Security.....	27
Data Validation – View Layer	27
Data Validation – Control Layer.....	27
Data Validation – Business Layer.....	27
Data Validation – Model Layer	28
Transactions	28
Notifications.....	28
Site Parameters.....	28
Concurrency	29
Overnight Processing	29
MPI Interaction	29
Sequence Diagrams.....	36
Search Sequence (multiple records returned)	36
Retrieve Data Sequence (single record returned).....	37
Store Sequence (save or update single record)	38
Remove Sequence (delete single record)	39
Data Conversion from Existing Applications	40
VIST 4.0 Data Conversion (VistA Application).....	40
Blind Rehabilitation Central Waitlist Application (Web based).....	40
Glossary/Acronym List.....	42
Index	48

Introduction

The Blind Rehab application provides enhanced tracking, and reporting, of the blind rehabilitation services provided to veterans by:

- Visual Impairment Service Teams (VIST) Coordinators
- Blind Rehabilitation Centers (BRCs)
- Blind Rehabilitation Outpatient Specialists (BROS)
- Visual Impairment Services Outpatient Rehabilitation (VISOR) Programs
- Visual Impairment Center to Optimize Remaining Sight (VICTORS)

Currently, there is no VistA software that meets the needs of the Blind Rehabilitation Centers or BROS and the VIST 4.0 package only monitors, tracks and reports on a limited amount of data for the VIST.

The site-based VIST 4.0 package will be replaced with the re-hosted Blind Rehabilitation (BR) Version 5.0 application supporting the HealthVet enterprise architecture. In addition to providing the base functionality of the version 4.0 system, BR Version 5.0 will provide a web-enabled GUI through which users can access enhanced capabilities intended for VIST Coordinators, new functionality for BROS, BRC personnel and waiting times and waiting list.

The Blind Rehabilitation Version 5.0 application will provide entirely new functionality that will encompass and integrate all five segments of the Blind Rehabilitation Services including waiting times and waiting list.

The Blind Rehabilitation Technical Manual/Security Guide gives a technical description of the application and the security features. The intended audience of this guide is IRM, EMC, EVS, SQA, and developers supporting the Blind Rehabilitation product.

Benefits

- Complies with Health_eVet-VistA Architecture
- Complies with 508 regulations, using W3C standards
- Accessible web based application, via a web browser
- Supports the OI Single Sign-on initiative
- User authentication via role based permissions
- User friendly
- Seamless continuum of care
- Minimum user disruption
- Simplified data entry
- Better identification and treatment of veterans
- Consolidates data
- Enables system driven waiting times and waiting list tracking and reporting capabilities
- Enables users to receive comprehensive views of a patient's BR Services across institutions
- Facilitates data tracking and auditing capabilities
- Improves accountability
- Enhanced reporting features
- Provides Data Standardization which improves and provides consolidated data reporting
- Improved blind services tracking
- Enables Research and Provides Outcomes tracking and reporting capabilities
- Improves VHA organizational communication
- Transmits to the Health Data Repository

Enhanced Technology

- A single consolidated database and application will replace the current site-specific VIST 4.0 package
- Fulfills the congressional mandate on waiting times and waiting list calculations
- Electronic referral process to track patient applications for service
- Notifications feature to alert users of pending referrals
- Encounters/Progress Notes will be automatically created for assessments and field visits (PCE interface) in a future version.
- Nationwide centralization of Blind Rehabilitation services data to allow nationwide reporting
- Ad-hoc reporting capabilities
- Secure Web Access (128 Bit SSL) from any authorized VA workstation
- Improved technology using web browser access and improved data security, via the VHA intranet
- Uses modern system architecture which allows for faster system enhancements
- Enhancements will be rolled out to all users at the same time ensuring consistent data
- Allows ability to track BR patient care access across institutions
- Patients can be referred or transferred to other institutions if they move without having to recreate patient data
- Patient lookup using the Health_eVet Person Lookup Service (PSL) and Person Service Demographics (PSC)
- Standardized lookup tables using the Health_eVet Standard Data Service (SDS)
- Improved data integrity
- Minimize the maintenance and support required by IT support staff

Vista Software Requirements

Before the installation of Blind Rehabilitation V5.0, the following packages must be installed and fully patched.

<i>Software</i>	<i>Version</i>	<i>Required Patches</i>	<i>HealthVet Dependency</i>
Kernel	V. 8	XU*8*238 XU*8*265 XU*8*284 XU*8*309 XU*8*337 XU*8*361 XU*8*343	XU*8*325 (Person Service Lookup Dependency) XU*8*329 (Kernel Authentication & Authorization for J2EE Weblogic)
Kernel Toolkit	V. 7.3	XT*7.3*89 XT*7.3*67	
VA FileMan	V. 22		
VistALink	V. 1.5.2.004		XOBU*1.5
RPC Broker	V. 1.1		
TIU	V. 1.0		
OERR	V. 3.0		
Registration	V. 5.3	DG*5.3*615 DG*5.3*620	DG*5.3*538 (Person Service Lookup) DG*5.3*557 (Patient Services)

HealthVet-VistA Software Requirements

During the installation of ¹Blind Rehabilitation 5.0.29.4, the following java packages are used. These components are supplied with the Blind Rehab software distribution zip file and are installed at the Centralized application server.

<i>Software</i>	<i>Version</i>
² VistALink	V 1.5.2.004
³ Kaajee	V 1.0.1.003
Kaajee SSPI	V 1.0.0.010
Person Service Lookup (PSL)	V. 4.0.4.4
Person Service Construct (formerly Person Service Demographics. Referred to as PSC or PSD)	V. 2.0.0.7
⁴ Standard Data Service	API V 18.0 Database V 18.0

Orientation

Recommended Users

The intended audience for the Blind Rehabilitation 5.0 Technical and Security Guide includes:

Information Resource Management (IRM)
Enterprise VistA Support (EVS)
Health Systems Implementation, Training and Enterprise Support (HSITES)
Enterprise Management Center Office (EMC)

Related Manuals

Blind Rehabilitation V. 5.0 VistA Installation/Implementation Guide
Blind Rehabilitation V. 5.0 Centralized Server Installation/Implementation Guide
Blind Rehabilitation V. 5.0 Release Notes
Blind Rehabilitation V. 5.0 User Manual
Online Help is available from within the application

¹ Changed version number of Blind Rehabilitation from 5.0.27.6 to 5.0.29.4

² Changed version number of VistaLink from 1.5.0.026 to 1.5.2.004

³ Changed version number of Kaajee from 1.0.0.019 to 1.0.1.003

⁴ Changed version number of Standard Data Service Database from 10.0 to 18.0

Documentation Retrieval

You can find the documentation files for Blind Rehabilitation on the OI Field Office [ANONYMOUS.SOFTWARE] directories.

<i>File Name</i>	<i>Description</i>	<i>Retrieval Format</i>
ANRV5_0CIG.PDF	Centralized Installation/Implementation Guide	Binary
ANRV5_0VIG.PDF	VistA Installation/Implementation Guide	Binary
ANRV5_0RN.PDF	Release Notes	Binary
ANRV5_0TM.PDF	Technical/Security Manual	Binary
ANRV5_0UM.PDF	User Manual	Binary

* This Installation Guide is only for Centralized Servers, not to be used at the field VistA site.

** This Installation/Implementation Guide is for field VistA sites.

VistA Intranet

Documentation for this product is available on the intranet at the following address:

<http://www.xx.xxx/vdl/>.

This address takes you to the VistA Documentation Library (VDL), which has a listing of all the clinical software manuals. Click on the Visual Impairment Service Team (VIST) link and it will take you to the Blind Rehabilitation documentation.

The link below allows access to the Blind Rehabilitation Services home page:

<http://www1.xx.xxx/blindrehab/>

Implementation and Maintenance

Please refer to the *Blind Rehabilitation v. 5.0 Installation/Implementation Guides* for additional information about installing and implementing the software.

Implementation is comprised of a centralized application:

Hosted in Hines Data Center

Interfaced to all field VistA servers via VistALink connections.

Information accessed through VistA Link RPCs

Installation of Blind Rehab KIDS build at each VistA site

User setup on local VistA and central Blind Rehab application

BR Production Centralized Server Deployment

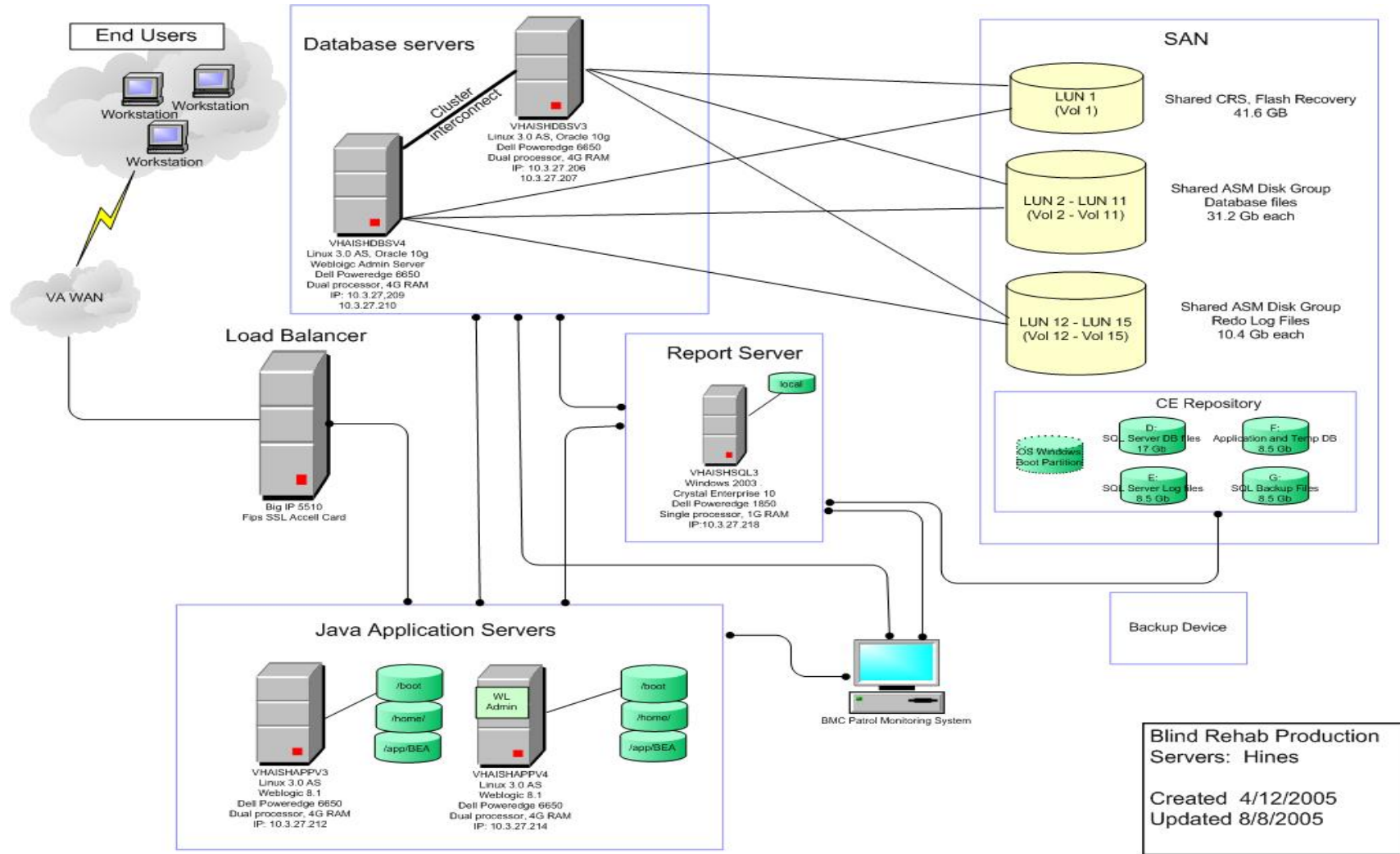

BR Sample Configuration

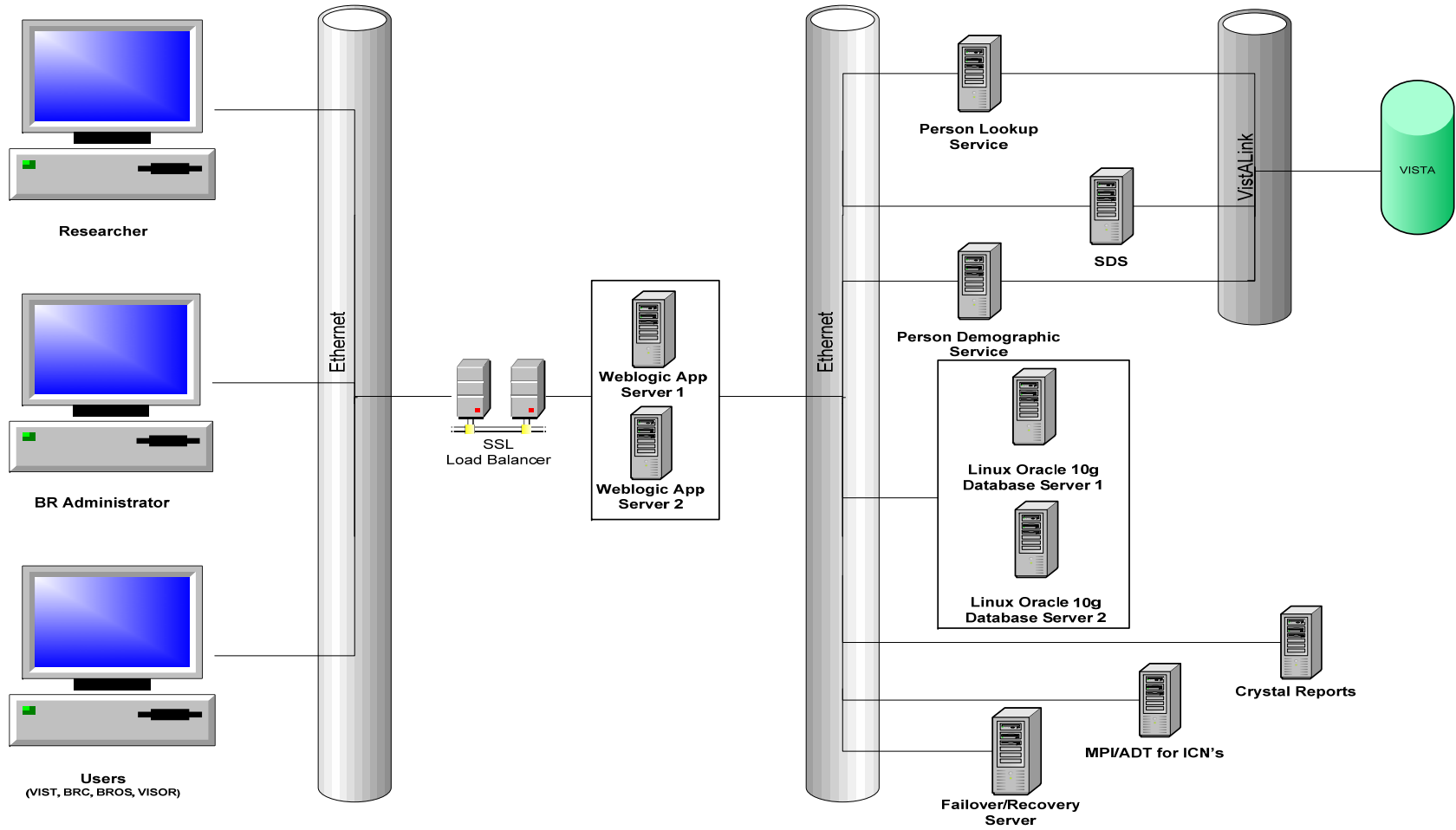

VistA Files

There are no files added to VistA with this software.

Routines

The following routines are included in the Blind Rehabilitation software:

<i>Routine</i>	<i>Description</i>
ANRVJ1	VistA routine used for interfacing to VistA until services are available.
ANRVP	Post installation routine

Security Keys

The following VistA file 200 Security Keys are included in the Blind Rehabilitation software:

<i>Routine</i>	<i>Description</i>
ANRVUSERROLE	This key is used for Authorization by KAAJEE in combination with the option to allow a user access to the Blind Rehabilitation software. All users of the system must have at minimum the ANRVUSERROLE security key and ANRVJ_BLINDREHAB Option.
ANRVADMINROLE	Security key for Administrators of the system.

Exported VistA Options

The option menus exported by Blind Rehabilitation are all located in the ANRV namespace. A number of options are deleted at the site and 1 new option is added to allow access to the Blind Rehabilitation software.

<i>Internal Entry Name</i>	<i>Option Name</i>	<i>Action</i>	<i>Description</i>
ANRVJ_BLINDREHAB	BLIND REHAB/VIST 5.0	Send to Site	Added to VistA this option allows access to the RPC's at the local site for Blind Rehabilitation 5.0
ANRV DELETE REFERRAL	Delete VIST Referral Roster	Delete At Site	Removed from VistA
ANRV DELETE ROSTER	Delete VIST Patient Record	Delete At Site	Removed from VistA
ANRV EDIT VIST OPTIONS	Edit VIST Options Menu	Delete At Site	Removed from VistA
ANRV ENTER/EDIT CHECKLIST	Enter/Edit VIST Benefits Checklist	Delete At Site	Removed from VistA
ANRV ENTER/EDIT INACTIVE VIST	Enter/Edit Inactive VIST Roster	Delete At Site	Removed from VistA
ANRV ENTER/EDIT REFERRAL	Enter/Edit VIST Referral Roster	Delete At Site	Removed from VistA
ANRV ENTER/EDIT VARO CLAIMS	Enter/Edit VARO Claims Roster	Delete At Site	Removed from VistA
ANRV ENTER/EDIT VIST LETTER	Edit VIST Letter	Delete At Site	Removed from VistA
ANRV ENTER/EDIT VIST PARAMETER	Enter/Edit VIST Parameter	Delete At Site	Removed from VistA
ANRV ENTER/EDIT VIST PATIENT	Enter/Edit VIST Patient Record	Delete At Site	Removed from VistA
ANRV EYE DIAG NARRATIVE	Eye Diagnosis Narrative	Delete At Site	Removed from VistA
ANRV LETTER MENU	VIST Letter Menu	Delete At Site	Removed from VistA
ANRV PATIENT REVIEW	ANRV PATIENT REVIEW RPC'S		

Parameter Definition

The following Parameter Definition is included in the Blind Rehabilitation software:

<i>Parameter</i>	<i>Description</i>
ANRV GUI VERSION	This site parameter is installed in VISTA in the PARAMETERS file 8989.5 automatically by the ANRVJP post installation routine using KIDS. The parameter allows the Blind Rehabilitation application to check the VistA sites software version and will not allow users to log into the system if the remote system is not running the correct version.

Remote Procedure

The following Remote Procedures are included in the Blind Rehabilitation software and are installed in the REMOTE PROCEDURE File (# 8994):

<i>Remote Procedure</i>	<i>Description</i>
ANRV CREATE ENCOUNTER	This RPC is for future use.
ANRV GET PN TITLES	This RPC is for future use.
ANRV PROBLEM LIST	This RPC gets a patients problem list to display in Blind Rehab.
ANRVJ1_RPC_MAIN	This is the main RPC entry point.

Required Builds

The following VistA Builds must be installed or the ANRV*5.0 KIDS will not load, during installation these are checked to ensure the VistA system is compatible with the Blind Rehab software.

<i>Build</i>	<i>Description</i>
DG*5.3*538	Uniform API used by the Person Service Lookup component of Blind Rehabilitation.
DG*5.3*557	Uniform API used by the Person Service Demographics and Construct component of Blind Rehabilitation.
XOBV 1.5	Uniform API used by the VistALink component of Blind Rehabilitation this allows for communication to the VistA DB.
XU*8.0*329	Uniform API used by KAAJEE (Kernel Authentication and Authorization for J2EE Weblogic) this is the security mechanism used to ensure users have appropriate security credentials for using the Blind Rehab application.

External Interfaces

	<i>Screen</i>	<i>Data Elements</i>	<i>Interface Via</i>	<i>Description</i>
1	Patient Lookup	ICN PATIENT_NAME PATIENT_ADDRESS PATIENT_CITY PATIENT_STATE PATIENT_ZIP PATIENT_HOME_PHONE PATIENT_BIRTH_DATE	VistALink	Provides a uniform patient lookup using VA standards
2	Enter Blind Rehab Staff	DFN PERSON_NAME	VistALink	This uses an RPC to get user data from the VistA site and is used for adding users to the system
2	Enter Blind Rehab Staff – Alternative 2	VPID (VA Person Id) PERSON_NAME	Person Service	Covers access to Person Identifying data in the VistA 200File. (Providers, Employees, IT Users
3	Single Sign On	VPID/ICN PERSON_NAME	KAAJEE	Single Sign On provides a service to allow the user to sign in once
5	PCE Problem List	DFN PROBLEM_LIST	Problem List DBIA446	Used to display the patients Problems List
6	Registration Screen	PRIMARY_ELIGIBILITY	Patient file (#2.361) DBIA3789	From Registration, Patient file #2

Database Integration Agreements (DBIAs)

The following is a list of approved DBIAs for Blind Rehabilitation.

DGRR GUI PATIENT LOOKUP	#4686
DGRR PATIENT SERVICE QUERY	#4686
GET DFN^MPIF001	#2701
DATA2PCE^PXAPI	#1889 (future use)
SELECTED^VSIT	#1905 (future use)
TIU SIGN RECORD	#1790 (future use)
TIU REQUIRES COSIGNATURE	#1800 (future use)
TIU CREATE RECORD	#1806 (future use)
TIU DELETE RECORD	#1811 (future use)
TIU GET PN TITLES	#1782 (future use)
FEE BASIS	#2347 (future use)
ORQQPL LIST	#1642

Software Product Security

Blind Rehabilitation implements Single Sign-on (SSO) based on established VHA and HSD&D requirements. To fulfill these requirements, the Blind Rehabilitation uses the Java Authentication and Authorization Service (JAAS) API via the HealthVet KAAJEE product. Users of the system can access Blind Rehabilitation by entering their current VistA Access and Verify Codes along with their institution. The users information is checked against the VistA system first by authenticating their access, verify code, and institution combination. Then they are authenticated by checking to ensure they have the appropriate Option Menu (ANRVJ_BLINDREHAB) and Security Key (ANRVUSERROLE) from VistA against the KAAJEE Weblogic security principle that uses both the principle and Oracle database entries to allow or disallow user access to the Blind Rehabilitation application. Additional authentication occurs inside the Blind Rehabilitation software to ensure the user has access to the VistA institution and to provide the user with a session containing the Blind Rehabilitation application menus assigned to that user within the application. Users with correct login credentials are allowed access to the application and can only access the menus that have been assigned to them.

Patient and user context management via CCOW was added to the application, however it is currently disabled due to accessibility (Section 508) issues created by the CCOW applet. CCOW will be re-enabled in a future release following the resolution of the introduced accessibility issues.

Secure socket layer (128Bit - SSL) encryption is used to protect data that is transmitted between the browser and the Web server.

The security layer is designed to insulate Blind Rehabilitation from requiring major changes as the underlying enterprise security system evolves. Blind Rehabilitation provides an abstraction in the form of Java interfaces, which allow for flexibility in the implementation.

Blind Rehabilitation provides the following:

Authentication – provided by wrapping the JAAS authentication mechanism, implementation for authentication must be provided by modules that provide the support

Authorization – provided by wrapping the JAAS authentication mechanism based on multiple principal subjects. Authorization is based on actions authorized by access control as defined by JAAS.

Audit – a function is provided by the supporting back end security system. Audit is not a front-end client based feature and is not defined in JAAS or the Security Module interfaces.

Security Management

Data contained in and messaged to BR is compliant with all applicable organizational and legislative security and privacy policies (for example, Health Insurance Portability and Accountability Act (HIPAA), the Privacy Act of 1996); Veterans Health Administration's Authentication, Authorization, Accountability (AAA) standards, guidance and procedures established by the VHA Health Information Security Office, and policy and guidance issued by the Department of Veterans Affairs Office of Cyber Security.

Strategic Initiatives Overview

The securing of data by controlling and recording access to it is paramount. Efforts that are external to the BR Project are also underway to ensure the security of data. The following efforts, although external to the BR Project, will influence the provision of security for the project:

The VA and VHA have each developed enterprise architectures that call for the introduction of a Common Health Information Security Services (CHISS) function. In a common health information security services design, functions such as user authentication and high-level authorization are processed by a 'common' or shared application instead of the old model of performing those functions inside each application.

The Interim Security Services for Rehosted Applications (ISSRA) project will serve as a bridge between the current security model and the one that will be implemented as CHISS. ISSRA will provide the user authentication and authorization services; Blind Rehab will be a 'customer' of ISSRA and will work closely with that team to ensure that the security requirements are completely and accurately defined. The current ISSRA security component used in Blind Rehabilitation is KAAJEE. At some future time, KAAJEE will be replaced with an Enterprise level authentication/authorization component.

Application Security

- Security risks to BR are mitigated by:
- Java Secure Coding Guidelines
- Single Sign-on (SSO)/KAAJEE
- Role-based Access
- Audit Trail
- Network Security
- 128bit SSL (HTTPS) Access to Web Server
- BR Site Server Security
- Physical Security

Audit Trail

An audit trail creates retrievable record of the users' interactions with the system. The ability to trace users to edits of specific records creates an identification that can be accessed in the event of a security breach or system defect.

The audit trail starts when a user accesses, submits a new record, or updates an existing record. The user ID is captured from their login and is stored in the audit trail along. The stored record has supporting classes that can be called by the system for reporting information about user transactions.

Remote Systems

This system connects to remote VistA systems throughout the organization. The data transmitted from a user's desktop to the Blind Rehab web server is encrypted through 128bit SSL (HTTPS). Data transmitted from the application server to the remote VistA sites and to the MPI over the VA Intranet is not encrypted.

Archiving/Purging

Archiving and purging capabilities are not currently available and were not requested or required.

Contingency Planning

Sites utilizing Blind Rehabilitation 5.0 should develop a local contingency plan to use in the event of product problems in a live environment. The facility contingency plan must identify the procedure for maintaining functionality provided by this package in the event of system outage. Field station

Information Security Officers (ISOs) may obtain assistance from their Regional Information Officer (RISO).

Electronic Signatures

N/A at this time.

Security Keys

ANRVUSERROLE and ANRVADMINROLE are VistA security keys used by this product to enhance the “strong” security of KAAJEE.

File Security

No new VistA files are distributed with this product.

Reference

Researchers have access to the Blind Rehabilitation application in accord with Patient Care Services Information Letter 11-2002-002 and the Federal Register Volume 66, Number 103, Pages 29209-29212.

Official Policies

Blind Rehabilitation 5.0 software release references no official policy unique to the product regarding the modification of software and distribution of the version.

Blind Rehabilitation Application

Blind Rehabilitation is designed to run on a J2EE 1.3 compliant application server running on a 1.4 JVM.

Enterprise Archive

BR deploys as a java enterprise archive named `BR-EAR-major.minor.revision.buildnumber.ear` containing the following elements. Example file name:⁵ `BR_APP_5.0.29.4.ear`.

Application.xml

This file exists in the META-INF directory per the java enterprise 1.3 specifications. This file describes the modules of the EAR file, which includes **BREJBModule.jar** and **BRWebModule.war**.

Weblogic-application.xml

This file exists in the META-INF directory. This is a basic deployment descriptor for WebLogic applications. No special or proprietary settings are used in this deployment descriptor.

APP-INF Directory

The APP-INF/lib directory contains external jar files needed for the BR enterprise application:

<i>Library Name</i>	<i>Description</i>
CAIP.jar	VA CAIP
cecore.jar	Business Objects Crystal Enterprise
celib.jar	Business Objects Crystal Enterprise
ceplugins.jar	Business Objects Crystal Enterprise
cereports.jar	Business Objects Crystal Enterprise
cesession.jar	Business Objects Crystal Enterprise
commons-beanutils.jar	Apache-Jakarta Commons
commons-collections.jar	Apache-Jakarta Commons
commons-digester.jar	Apache-Jakarta Commons
commons-fileupload.jar	Apache-Jakarta Commons
commons-httpclient-2.0.1.jar	Apache-Jakarta Commons
commons-lang.jar	Apache-Jakarta Commons
commons-logging.jar	Apache-Jakarta Commons
commons-resources.jar	Apache-Jakarta Commons
commons-validator.jar	Apache-Jakarta Commons
CorbaIDL.jar	Business Objects Crystal Enterprise
CrystalCharting.jar	Business Objects Crystal Enterprise
CrystalCommon.jar	Business Objects Crystal Enterprise
CrystalExporting.jar	Business Objects Crystal Enterprise
CrystalFCM.jar	Business Objects Crystal Enterprise
CrystalFormulas.jar	Business Objects Crystal Enterprise
CrystalQueryEngine.jar	Business Objects Crystal Enterprise
CrystalReportEngine.jar	Business Objects Crystal Enterprise
ebus405.jar	Business Objects Crystal Enterprise
hapi-0.4.3.jar	Open source HL7 API (Sourceforge)
itext-1.02b.jar	Open source JAVA-PDF (Sourceforge)

⁵ Changed version number of BR from 5.0.27.6 to 5.0.29.4

<i>Library Name</i>	<i>Description</i>
jakarta-oro.jar	Apache-Jakarta ORO
jakarta-regexp-1.3.jar	Apache-Jakarta Regular Expressions
junit.jar	Open source Test Class (Sourceforge)
kaajee-1.0.1.003.jar	VA KAAJEE Client
keycodeDecoder.jar	Business Objects Crystal Enterprise
log4j-1.2.8.jar	Apache-Logging
log4jVLJconfig.jar	VA VistaLink config files
LongList.jar	VA Person Service Lookup (PSL)
MetafileRenderer.jar	Business Objects Crystal Enterprise
MPIListener.jar	BR MPI Listener
NamingDirectoryService-client.jar	VA CAIP
PatientServiceR2.jar	VA Person Service Construct
pslWeb_4.0.4.4.jar	VA Person Service Lookup (PSL)
rasapp.jar	Business Objects Crystal Enterprise
rascore.jar	Business Objects Crystal Enterprise
ReportTemplate.jar	Business Objects Crystal Enterprise
rpoifs.jar	Business Objects Crystal Enterprise
Serialization.jar	Business Objects Crystal Enterprise
struts.jar	Apache Struts
URIUtil.jar	Business Objects Crystal Enterprise
vha-stddata-basic-18.0.jar	VA Standard Data Service
⁶ vha-stddata-client-18.0.jar	VA Standard Data Service
WebJContextor.jar	Sentillion CCOW
webreporting-advanced.jar	Business Objects Crystal Enterprise
webreporting-core.jar	Business Objects Crystal Enterprise
webreportingtags.jar	Business Objects Crystal Enterprise
WebReportWizard.jar	Business Objects Crystal Enterprise
xercesImpl.jar	Apache – Xerces XML Parser
xmlParserAPIs.jar	XML Parsing

⁶ Changed version number of SDS Database Jars from 10.0 to 18.0

Web Archive File

The BR enterprise archive contains the BR web archive, **BRWebModule.war**. The file contains a root directory, virtual directories, and the WEB-INF directory.

Directory Contents

<i>Directory Name</i>	<i>Description</i>
/	Root directory contains entry, home, layout, tile definition and other root level pages
Admin	BR Administrative pages
assessmentTrainingEncounter	BR Assessment and Training pages
benefitsChecklist	BR Benefit Checklist pages
Brstaff	BR Staff (User setup) pages
Ccow	BR-CCOW pages
clinicalAssessment	BR Clinical Assessment Pages
Common	BR Common pages and JavaScript files
Css	BR Stylesheet files
crystalreportviewers10	Business Objects Crystal Report viewer pages and resources
educationInService	BR Education and In-service pages
Encounters	BR Encounter pages
eyeExam	BR Eye Exam pages
help	BR Help pages and resources
images	BR Web related images
letters	BR Letter pages
lib	Sentillion CCOW applet resources
login	KAAJEE Login pages and resources
menu	BR Menu pages
patient	BR and PLU(PSL) patient related pages
plu	PLU related patient resources
referrals	BR Referral pages
reports	BR Report criteria and Individual report response pages
reviews	BR Reviews (Annual Outcome Survey and Pre-Post Review) pages
stylesheets	PLU Stylesheet files
test	BR Various development test pages
user	BR Login pages prior to KAAJEE integration (deprecated)
varo	BR VARO Claim pages
vista	BR Various development test pages for VistA functions
vistAnnualReview	BR VIST Annual Review pages
vistFieldVisits	BR VIST Visits pages
waitlist	BR Waitlist Record search, list, and edit pages

<i>Directory Name</i>	<i>Description</i>
WEB-INF	Various deployment descriptor, tag library descriptor, tile definition descriptor, struts config, and other descriptor files
WEB-INF/classes	BR Java Classes used by the Web module

Web Archive web.xml File

The BR Web module archive contains a file named web.xml. This file contains:

Context parameters

Servlets

Servlet mappings

Filters

Filter mappings

Security roles

Security constraints

(KAAJEE) login configuration

Taglib declarations

Welcome files

Error pages

Listeners

Web Archive Weblogic.xml File

Weblogic.xml contains the mapping of the logical Java enterprise role to the physical WebLogic security realm.

Struts Config Files

Weblogic.xml contains the mapping of the logical Java enterprise role to the physical WebLogic security realm.

EJB Archive File

The Blind Rehab Enterprise Java Beans and related classes are packaged as an ejb jar file named **BR.EJBModule.jar**. The deployment descriptors are located in the META-INF directory and classes in the ejb jar's gov/va/med/br. directory. All EJBs in Blind Rehabilitation are Stateless Session Beans. BR does not use Stateful Session, Entity, or Message Driven Beans.

BR deploys the following local and remote ejbs:

AdtSession
AgencyTypeSession
AnnualReviewSession
ApplicationStateSession
BenefitsChecklistSession
BRCClinicalAssessmentSession
BROSClinicalAssessmentSession
BROSVisitSession
ClinicalAssessmentSession
CrystalReportHelperByVisnSession
CrystalReportHelperSession
DataMigrationSession
DivisionSession
EducationInServiceSession
EyeExamSession
IcnUpdateSession
InstitutionSession
LetterSession
MPIRegistrationSession
NotesSession
PatientSession
PCESession
PrePostReviewSession
PsdSession
ReferralSession
ReferralStatusSession
RoleSession
SecuritySession
ServiceAreaSession
SiteParameterSession
StandardDataServiceSession
TrainingSession
VAROClaimSession
VistaLinkSession
VistAnnualReviewSession
VistFieldVisitSession
WaitlistSession

The Ejb-jar archive contains the following descriptors:

Ejb-jar.xml contains the following elements:

Session beans – all BR ejbs are stateless session beans. EJB is primarily used for declarative method security and future scalability.

Method permissions

Container transactions

Weblogic-ejb-jar.xml contains:

Weblogic enterprise beans – important for the JNDI address of each bean

Weblogic security roles – the mapping of logical java enterprise roles to physical WebLogic security roles.

Application Property Files

Blind Rehab uses several property files to control its runtime behavior. The files are located on the file system in the /conf directory. These include:

Application.properties – the main property file containing settings for the application. Deployed on the file system.

Log4j.properties – property file used to control the logging behavior of the application. Deployed on the file system. Has default settings for log file appenders, file names, file rotation, logging format, and socket appenders.

ApplicationResources.properties – property file that controls the struts resources. This includes button and label text display in the application. Deployed in the WAR file. (/WEB-INF/classes)

chainsaw_startup.xml – property file to start a socket receiver when starting Chainsaw. Chainsaw is optional; this file is provided to help start it with settings consistent with the default log4j.properties file. Deployed on the file system.

Other Configuration Files

WEB-INF contains the KAAJEE configuration file kaajeeConfig.xml as well as the BR and PSL struts config files (struts-config.xml and struts-config-plu.xml respectively).

BR also depends on the following service dependency configuration files that need to be configured during deployment:

Application.properties

ApplicationResource.properties

PatientLookup.properties

PersonLookupResources.properteis

PatSvcPkg.properties

KaajeeDatabase.properties

gov.va.med.vistalink.connectorConfig.xml

SDS's configuration file

a PSL configuration file

a PSL configuration file

a PSL configuration file

a PSC configuration file

a KAAJEE configuration file

a VLJ configuration file

Please review the Blind Rehab Centralized Installation manual and the respective Health_eVet Component documentation for more information on these configuration files.

Exceptions

Blind Rehab uses the following exceptions:

gov.va.med.br.bo.ParameterOutOfRangeException
gov.va.med.br.dao.DAOClinicKeyRetrievalException
gov.va.med.br.dao.DAOConnectionException
gov.va.med.br.dao.DAODivisionKeyRetrievalException
gov.va.med.br.dao.DAOException
gov.va.med.br.dao.DAOPatientDivisionKeyRetrievalException
gov.va.med.br.dao.DAORemovalException
gov.va.med.br.dao.DAORetrievalException
gov.va.med.br.dao.DAOUpdateException
gov.va.med.br.dao.KeyGenException
gov.va.med.br.dao.MPIRegistrationException
gov.va.med.br.exceptions.UserException
gov.va.med.br.ui.HealtheVetPatientFindException
gov.va.med.br.ui.delegates.DelegateException
gov.va.med.br.ui.delegates.DelegateInitializationException
gov.va.med.br.util.AuditTrailException
gov.va.med.br.util.ServiceLocatorException

Service Imports

BR imports the following classes from VA services:

Standard Data Service (SDS)

gov.va.med.term.access.Institution
gov.va.med.term.access.Country
gov.va.med.term.access.State

VistaLink for Java

gov.va.med.vistalink.adapter.cci.VistaLinkAppProxyConnectionSpec
gov.va.med.vistalink.adapter.cci.VistaLinkCcowConnectionSpec
gov.va.med.vistalink.adapter.cci.VistaLinkConnection
gov.va.med.vistalink.adapter.cci.VistaLinkConnectionFactory
gov.va.med.vistalink.adapter.spi.VistaLinkConnectionManager
gov.va.med.vistalink.adapter.spi.VistaLinkManagedConnectionFactory
gov.va.med.vistalink.adapter.cci.VistaLinkConnectionSpec
gov.va.med.vistalink.adapter.cci.VistaLinkConnectionSpecImpl
gov.va.med.vistalink.adapter.cci.VistaLinkDuzConnectionSpec
gov.va.med.vistalink.adapter.cci.VistaLinkVpidConnectionSpec
gov.va.med.vistalink.adapter.record.VistaLinkFaultException
gov.va.med.vistalink.institution.InstitutionMappingDelegate
gov.va.med.vistalink.institution.InstitutionMapNotInitializedException
gov.va.med.vistalink.institution.InstitutionMappingNotFoundException
gov.va.med.vistalink.rpc.RpcRequest
gov.va.med.vistalink.rpc.RpcRequestFactory

gov.va.med.vistalink.rpc.RpcResponse

KAAJEE

gov.va.med.authentication.kernel.LoginUserInfoVO

Patient Service Lookup (PSL)

gov.va.med.person.lookup.patient.transfer.IUserBean

gov.va.med.person.lookup.common.IPLUConstants

gov.va.med.person.lookup.patient.transfer.PatientLookupBean

gov.va.med.person.lookup.ui.web.common.*

Patient Service Construct (PSC)

gov.va.med.patientadmin.delegate.PatientServiceRequest

gov.va.med.patientadmin.common.RequestType

gov.va.med.patientadmin.transfer.*

gov.va.med.patientadmin.common.IIdentifier

gov.va.med.patientadmin.common.IVistaDate

gov.va.med.patientadmin.common.IAddress

gov.va.med.patientadmin.common.AddressType

gov.va.med.patientadmin.common.Ethnicity

gov.va.med.patientadmin.common.Alias

gov.va.med.patientadmin.common.Race

gov.va.med.patientadmin.delegate.*

gov.va.med.patientadmin.exception.*

Java Enterprise Developer Workstation

Blind Rehab java enterprise developer workstations are dependent on remote and local services. All VA java service dependencies are generally deployed locally on the developer's workstation to isolate development work from external problems.

Development Platform

The following infrastructure was used to develop Blind Rehabilitation on Windows workstations:

<i>Application</i>	<i>Description</i>
Sun Java JDK 1.4.2	Java compiler. JAVA_HOME must be set to the base directory where this is installed.
WebLogic Server 8.1 sp 4	All developers need to setup local WebLogic servers on their workstations.
Eclipse 3.1 and MyEclipse 4.0 Plugin	Eclipse 3.1 with the MyEclipse 4.0 plugin is the official IDE for BR 5.0. Any suitable text editor may be used however.
Internet Explorer/Netscape Navigator	Blind Rehab is a web application; therefore, developers are required to have VA supported versions of browsers installed.
Source Control Management	Microsoft Visual Source Safe v6.0c. BR Repository is: \\VHAISHFPC2\Vss root directory is: \$/Blind Rehab V5.0/Development
Cache v4	Cache is needed to support a Vista environment for VistALink interaction. Remote instances are preferred, but local Cache instances can be used.
Oracle 10g	Oracle 10g database may be setup locally or remotely for development. SQLPUS or other capable SQL client may be used to access Oracle. Command line scripting of sql scripts must use SQLplus.
Crystal Reports v10	The Crystal Reports designer tool is needed on developer workstations who create or maintain the defined (non Adhoc) reports.
Crystal Enterprise v10	A remote instance of Crystal Enterprise 10 is used to publish and execute developed reports.

Development Projects

BR is comprised of two projects in the source control management system. Each project is built with ANT. Each project has its own **build.xml** and **build.properties** files. The **build.xml** files have the targets described below. The **build.properties** files contain local settings for classpaths, URLs and other parameters. The two projects are:

\$/Blind Rehab V5.0/Development – the base project containing the BR application, and all compile-time/runtime libraries. Includes the following build targets:

Ant build (default target) – compiles all files and generates JAR, WAR, EAR

Ant compile – only compiles the java classes

Ant deploy – all compilation and deploys to the server specified in the local **build.properties** file.

Ant zip – all compilation and created the BR zip distribution file.

Ant clean – removes class files and deployment archives

\$/MPIListener – Used to build the Blind Rehabilitation side of the MPI interface. This is required to be built before Blind Rehab. Building the MPIListener creates the MPIListener.jar file. This JAR file needs to be manually placed into the \$/Blind Rehab V5.0/Development/lib_healthevet/mpiListener/ directory as updates occur to it. It is then automatically included in the final Blind Rehab EAR deployment file during the main Blind Rehab build.

ant clean - removes class files and deployment archives

ant build – compiles all files and generates the MPIListener.jar file.

Development Tools

General development deployment of BR is done using the ANT **deploy** target in the **build.xml** file.

Developers using this target to deploy the application will also need to configure the **build.properties** file located in the development root directory to match their local environment.

ANT

ANT 1.6 is the build tool for Blind Rehab. Each project contains a build file in the root directory named **build.xml**.

Log4j

Log4j 1.2.8 is the logging tool used in the Blind Rehab logging framework. The logging framework is encapsulated in the **gov.va.med.br.util.BRLogger** class. This encapsulation isolates the system from changes in the logging tool. If the logging tool is replaced in a future version, only **gov.va.med.br.util.BRLogger** class should need to be modified.

Chainsaw

Chainsaw is a GUI Logging console supplied within LOG4J. This can be used as a socket receiver for LOG4J events and is very helpful during development and production support troubleshooting.

Libraries

Additional libraries are necessary for development and/or building of Blind Rehab. These libraries change over time and a current list is available in the Blind Rehab **build.xml** file of each project.

HealthVet Services

The following VA services are deployed locally in a Weblogic server:

SDS
VLJ
KAAJEE
PSL
PSC

SDS

⁷ Standard Data Services API V. 18.0, Database V 18.0 is the version used by Blind Rehab.

VLJ

Vista Link Java 1.5 is the version used by Blind Rehab.

KAAJEE

Kernel Authentication Authorization Java Enterprise Environment 1.0 is the version used by Blind Rehab.
KaaJee Security Provider 1.0.0.010 is the version used by Blind Rehab.

PSL

Person Service Lookup 4.0.4.4 is the version used by Blind Rehab.

PSC (formerly PSD)

Patient Service Construct R2 is the version used by Blind Rehab.

⁷ Changed version of Standard Data Service Database from 10.0 to 18.0

Business Rule Implementation

Web Security

The BR menu options are created dynamically based on the roles that a user has assigned to them. Users are not presented with menu links that are outside of their roles.

Select lists that contain Institutions in primary user functions are loaded only with Institutions assigned to that user. Select lists in administrative and program office functions are loaded with the complete Institution list for Blind Rehabilitation services.

Data Validation – View Layer

Data entry validations are generally performed by JavaScript in each data entry page. This is done to provide immediate feedback to the user for correction and place focus on the data element responsible for the problem. This also removes the overhead of a complete http post operation just to determine that a data entry field may be invalid. Business rules are not implemented in the pages except where validation of one field depends on the value entered in another field.

Data Validation – Control Layer

Blind Rehabilitation uses the open source STRUTS Framework to assist in the flow between pages and initiate the actions performed as pages are submitted. Blind Rehab extends the STRUTS Action classes in the gov.va.med.br.ui.struts.actions package to provide the control layer of the application. The BR action classes determine which function a user is intending to perform and either forward to the proper page or call business delegates to perform a transaction, and then forward to the result page. The action classes create Blind Rehab data objects from the submitted page values and validate entries at that time. The action classes also verify proper session state before performing transactions.

Data Validation – Business Layer

The Business Layer in BR consists of the business delegates and enterprise java beans (EJB). The business delegates validate the business function that a user is attempting to conduct, performs audit trail recordkeeping, create User Transaction contexts for update transactions, and call the appropriate EJB(s) to conduct the transaction. The EJB classes call the appropriate data access object(s) (DAO) to interact with the database or VistA.

Data Validation – Model Layer

Model objects in Blind Rehab are contained in the gov.va.med.br.bo and gov.va.med.br.dto packages. These objects help control data validation by using private data attributes, multiple constructors, and getter/setter methods.

Final data integrity checks are performed by the gov.va.med.br.dao package and database DDL. Most BR DAO classes access only the Oracle database. These ‘internal’ data DAO’s manage record keys, data format conversions, and conversion of improper null values to valid empty values. The Oracle database schema DDL contains a significant number of constraints that describe primary key columns, protect referential integrity, and ensure existence of all required (“not NULL”) fields.

Several DAO objects are capable of interfacing with VistA systems over the VistALink connectors. Data which is retrieved from or saved to VistA is handled and validated by these “external” data DAO’s.

Transactions

BR uses Java User Transactions to wrap all create and update functions. This allows for simple rollback of all steps in a failed transaction or full commit for successful transactions. BR does not use Java user transactions for query only functions. BR does not have any record deletion capability accessible from the user interface.

Transactions can only be performed by the running Blind Rehab application (system user) or a fully logged in and authorized Blind Rehab user account. All transactions are logged to the AUDIT_TRAIL table with the identity of the user who performed it.

Transactions and the associated audit trail record cannot be undone or deleted through any UI provided facility. Because transactions can affect multiple data records in complex interactions, rolling back a transaction requires investigation of the data affected and a planned course of action to revert any changes. This will need to be a coordinated effort between the user, Tier 2 support, and Tier 3 support.

Notifications

Notifications are currently in use only for newly created referrals. Upon login, the system performs an automated referral search on behalf of the user. The referral search parameters are controlled by:

The logging in user’s roles (must be able to create or search for referrals)

The user’s assigned institutions (only searches with those institutions)

The ReferralAutoSearch parameters in the application.properties file (for number of days back and referral states to include)

After the search is complete and if referrals were found, a notification is added to the UserState object associated with the user’s http session. The list of notifications is displayed in the Home page. A URL anchor (link) is part of the notification and directs the user to the result list for that notification.

The notification framework is being enhanced to allow for multiple types of Notifications and to store them between logins. Starting in build 5.0.27.1, notifications are being used to alert users to patients who have become deceased.

Site Parameters

Site parameter functionality is currently under development for future versions of the application and will include the ability for application administrators to perform the following:

Create/modify BR Service Areas. (VIST, BROS, BRC, etc.)

Create/modify BR Servicing Institutions by associating a BR service area with a Standard Data Service Institution.

Create/modify causes for vision loss, ICD9 and CPT subsets for progress note creation, and other internal Blind Rehabilitation lookup table values.

Concurrency

BR uses optimistic concurrency. This is performed in the DAO layer. Prior to updating a record, the DAO will check the Modified Date/Timestamp of the object to be updated and compare it to the current record in the database. If the database record was updated after the user initially acquired the record (updated by another user), a Blind Rehab Exception is thrown to alert the user that they must refresh and re-edit the record they are modifying before saving is allowed. Database record locking was avoided because of its proprietary nature and access problems when a record lock is not released. A more sophisticated and non-proprietary in-memory object lock has been discussed and may be implemented later.

Overnight Processing

Blind Rehabilitation performs the following scheduled overnight processing:

Demographic updates for all patients. Because BR is a separate centralized database from the authoritative VistA servers where the patient data resides, it must be refreshed periodically to remain synchronized. This process is handled by the PSDUpdater class. PSDUpdater runs once every 24 hours at a start time defined in the application.properties file. The PSDUpdater first obtains a list of all Blind Rehab patients grouped by home Institution (station) and then uses the Patient Service Construct (PSC) to acquire full demographic updates for the patients from their originating VistA server. PSC has a batching mechanism, which currently allows retrieving updates for 500 patients in each batch. Demographic data such as name, address, date of birth, and date of death are updated. If a patient is discovered to have become deceased (has a date of death), they will be flagged as an inactive patient during this process as well. Starting in version 5.0.27.1, newly deceased patients will have any open referrals cancelled and a deceased patient notification will be generated to alert their tracking user.

MPI Interaction

The BR database stores Patient demographic data as a copy of the data that originated at a VistA server. Most demographic data can be updated during the overnight process, however, the key field for patients in VistA, the Integration Control Number (ICN) cannot be. Changes to a Patient ICN must be handled through interaction with the VA Master Patient Index (MPI). This interaction is conducted via direct HL7 messaging over TCP/IP sockets. For more information on the MPI related interaction and messages, please visit the MPI VDL link at <http://www.xx.xxx/xxx/Infrastructure.asp?appID=16>. During processing of these interactions, the HL7 messages are logged in the BR application log4j output file and stored in the audit trail table

Blind Rehabilitation-MPI interaction is composed of the following interactions:

Registering interest in a patient with the MPI system.

Upon initial save of a patient or after conversion of a patient record into BR, register interest in the patient with MPI. This is done by sending an HL7 QBP (Query By Parameter) and receiving an HL7 RSP (Response Segment Pattern) response:

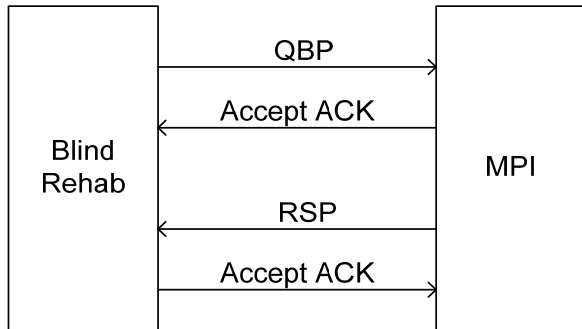

The Blind Rehabilitation application will be interested in any changes to patient identifier information. The Blind Rehabilitation application will send MPI a QBP message that will contain a fully qualified source system id (i.e. in your implementation that is station # and DFN) for each patient in which we are interested. There will be one QBP message per fully qualified source id of interest. MPI will then send an RSP message that will supply the fully qualified enterprise id (i.e. ICN and 200M) or a “No record Found” response that will be used to update the Blind Rehabilitation database. If an ICN is supplied the Blind Rehabilitation application should immediately update the ICN stored for the corresponding patient. If a “no record found” response is sent then the ICN provided either in the initial load or by the PS Lookup should be used until an unsolicited ADT-A24 is sent (see Linking of a source id to an ICN section). (See MPI Interface spec for specific examples). Note that the QBP is sent over a socket that is created by the Blind Rehabilitation application, and the Accept ACK is returned over the same socket. At this point, the socket is closed. The RSP message is then sent over a socket that is created by MPI and the Accept ACK is returned over this socket.

After successfully processing of the RSP, the patient is marked as registered by setting the MPI_REGISTERED column of the PATIENT table to ‘Y’. All patients in Blind Rehabilitation must be registered with the MPI. This is the only Blind Rehabilitation initiated MPI event.

Duplicate resolutions for enterprise systems (ICN Merge).

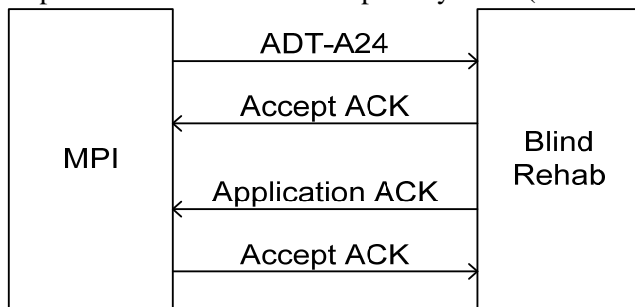

Example:

```
MSH^~|\&^MPIF TRIGGER^200M~MPI.FO-ALBANY.MED.VA.GOV~DNS^MPIF
TRIGGER^200BR~domainname~DNS^20041110132901-0500^^ADT~A24^200890416^T^2.4^^^AL^AL^
EVN^A24^20041110132901-0500
PID^1^^1008520398V272129~~~USVHA&&0363~NI~VA FACILITY
ID&200M&L|036664114~~~USSSA&&0363~SS~VA FACILITY
ID&553&L|7171324~~~USVHA&&0363~PI~VA FACILITY
ID&553&L^M^MPIPATIENT~ELEVEN~~~~L^MPIMAIDEN~~~~M^19690303^F^^^~
~NEW YORK CITY~36~~N^AAAAAAAAAAAAAAAA
^^^^^^
PD1^^^DETROIT,MI~D~553
PID^2^^1008520400V272129~~~USVHA&&0363~NI~VA FACILITY
ID&553&L|036664114~~~USSSA&&0363~SS~VA FACILITY ID&553&L|7171324~~~USVHA&&0363~PI~VA
FACILITY ID&553&L^M^MPIPATIENT~ELEVEN~~~~L^MPIMAIDEN~~~~M^19690303^F^^^~
~NEW YORK CITY~36~~N^AAAAAAAAAAAAAAAA
```

MPI will send the Blind Rehabilitation system notification when an enterprise ICN duplicate is found. An enterprise duplicate is defined as a patient having two or more ICN numbers assigned to them in MPI. For an enterprise duplicate, an ADT-A24 message will be sent. This message's first PID segment will contain the new patient identifier information, and the second PID will contain the old patient identifier information. Between these two PID segments, the DFN/Station Number will not change, but ICN will. Note that the ADT A24 is sent over a socket that is created by MPI, and the Accept ACK is returned over the same socket. At this point, the socket is closed. The Application ACK message is then sent over a socket that is created by the Blind Rehabilitation application and the Accept ACK is returned over this socket.

After successfully processing this ADT-A24, the patient is marked as 'Not-Selectable' in Blind rehab by setting the ICN_CHANGE_NOTIFICATION column of the PATIENT table to 'M' (for merge). Users will not be able to select or enter/edit data for the patient until a manual merge is completed. Since this event indicates that a patient has multiple records in the database, one primary patient record needs to be chosen and the duplicates removed. All the child records associated with the duplicate patient records will need to be associated with the proper patient record. This process involves caregiver decisions and cannot be automated. The caregiver will need to work with EVS support, IMDQ, BR developers, and the BR DBA to resolve the issue. Once the duplicate has been resolved, the DBA may manually set the ICN_CHANGE_NOTIFICATION indicator to 'N'.

This condition is rare but requires support assistance to resolve. To help resolve the event and respond proactively, an email message is generated when this event is processed. The email is sent to a mail group defined in the application.properties file with appropriate descriptions of the event. This email is intended to inform the EVS support group that manual clean up of a Blind Rehabilitation record is required and prompt them to contact the affected user.

Duplicate resolutions for source systems (ICN Merge).

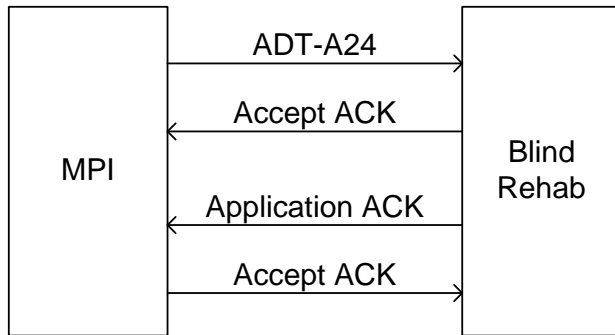

Example:

```

MSH^~|\&^MPIF TRIGGER^200M~MPI.FO-ALBANY.MED.VA.GOV~DNS^MPIF
TRIGGER^200BR~domainname~DNS^20041110132901-0500^^ADT~A24^200890416^T^2.4^^AL^AL^
EVN^A24^20041110132901-0500
PID^1^^1008520398V272129~~~USVHA&&0363~NI~VA FACILITY
ID&200M&L|036664114~~~USSSA&&0363~SS~VA FACILITY
ID&553&L|7171324~~~USVHA&&0363~PI~VA FACILITY
ID&553&L^M^MPIPATIENT~ELEVEN~~~~L^MPIMAIDEN~~~~~M^19690303^F^^~
~NEW YORK CITY~36~~~N^*****
*****
PD1^^^DETROIT,MI~D~553
PID^2^^10085203400V272129~~~USVHA&&0363~NI~VA FACILITY
ID&553&L|036664114~~~USSSA&&0363~SS~VA FACILITY ID&553&L|7171323~~~USVHA&&0363~PI~VA
FACILITY ID&553&L^M^MPIPATIENT~ELEVEN~~~~L^MPIMAIDEN~~~~~M^19690303^F^^~
~NEW YORK CITY~36~~~N^*****
*****
  
```

MPI will send the Blind Rehabilitation system notification when a source system duplicate is found. A source system duplicate is defined as a patient having two or more patient records assigned to them on a legacy VistA site. For a source system duplicate, an ADT-A24 message will be sent. This message's first PID segment will contain the TO patient identifier information (i.e. ICN and DFN), and the second PID will contain the FROM patient identifier information (i.e. ICN and DFN). Between these segments, the DFN/Station Number will change, and the ICN may or may not change. Note that the ADT A24 is sent over a socket that is created by MPI, and the Accept ACK is returned over the same socket. At this point, the socket is closed. The Application ACK message is then sent over a socket that is created by the Blind Rehabilitation application and the Accept ACK is returned over this socket.

After successfully processing this ADT-A24, the patient is marked as 'Not-Selectable' in Blind rehab by setting the ICN_CHANGE_NOTIFICATION column of the PATIENT table to 'M' (**for merge**). Users will not be able to select or enter/edit data for the patient until a manual merge is completed. Since this event indicates that a patient has multiple records in the database, one primary patient record needs to be chosen and the duplicates removed. All the child records associated with the duplicate patient records will need to be associated with the proper patient record. This process involves caregiver decisions and cannot be automated. The caregiver will need to work with EVS support, BR developers, and the BR DBA to resolve the issue. Once the duplicate has been resolved, the DBA may manually set the ICN_CHANGE_NOTIFICATION indicator to 'N'.

This condition is rare but requires support assistance to resolve. To help resolve the event and respond proactively, an email message is generated when this event is processed. The email is sent to a mail group defined in the application.properties file with appropriate descriptions of the event. This email is intended to inform the EVS support group that manual clean up of a Blind Rehabilitation record is required and prompt them to contact the affected user

Resolution of multiple patients sharing the same ICN (ICN Split):

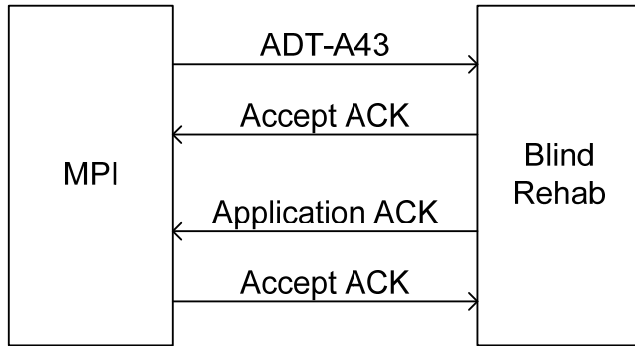

MPI will send the Blind Rehabilitation system notification when a fully qualified source id was erroneously linked to an ICN that resulted in two patients sharing the same ICN number. MPI will send an ADT-A43 in order to accomplish this notification. The ADT-A43 message’s PID segment will contain the TO patient identifier information (i.e. DFN and ICN), and the MRG segment will contain the FROM patient identifier information (i.e. DFN and ICN). Note that the ADT A43 is sent over a socket that is created by MPI, and the Accept ACK is returned over the same socket. At this point, the socket is closed. The Application ACK message is then sent over a socket that is created by the Blind Rehabilitation application and the Accept ACK is returned over this socket.

After successfully processing this ADT-A43, the patient is marked as ‘Not-Selectable’ in Blind Rehab by setting the ICN_CHANGE_NOTIFICATION column of the PATIENT table to ‘S’ (for split). Users will not be able to select or enter/edit data for the patient until a manual split is completed. Since this event indicates that two different people were associated with one patient ICN, a new patient record will need to be created and the appropriate child records associated with the appropriate patient. This process involves caregiver decisions and cannot be automated. The caregiver will need to work with EVS support, BR developers, and the BR DBA to resolve the issue. Once the duplicate has been resolved, the DBA may manually set the ICN_CHANGE_NOTIFICATION indicator to ‘N’.

This condition is very rare but requires support assistance to resolve. To help resolve the event and respond proactively, an email message is generated when this event is processed. The email is sent to a mail group defined in the application.properties file with appropriate descriptions of the event. This email is intended to inform the EVS support group that manual clean up of a Blind Rehabilitation record is required and prompt them to contact the affected user

Linking of a source id to an ICN (ICN Change):

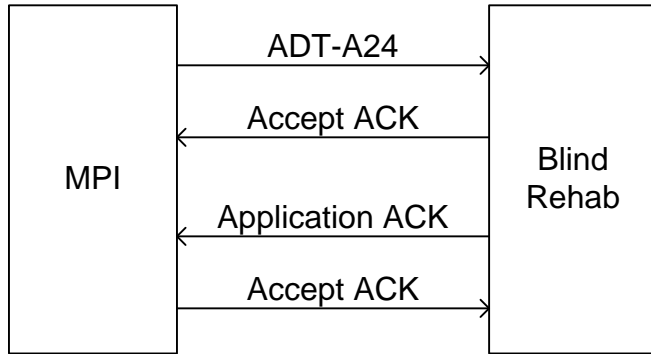

MPI will send the Blind Rehabilitation system notification for those fully qualified source system ids that have been previously registered via QBP (i.e. “No record found” from registering an interest in a patient with MPI). This message’s first and second PID segment will contain the TO patient identifier information (i.e. ICN and DFN). Note that the ADT A24 is sent over a socket that is created by MPI, and the Accept ACK is returned over the same socket. At this point, the socket is closed. The Application ACK message is then sent over a socket that is created by the Blind Rehabilitation application and the Accept ACK is returned over this socket.

After successfully processing this ADT-A24, the existing patient record is examined to see if the current ICN has changed. If the existing patient record is found, the INTEGRATION_CONTROL_NUMBER column of the PATIENT table is updated to the new ICN number in the message. This event does not disable the patient for selection. Users will be unaware that this event has occurred, as they cannot view the ICN number in the Blind Rehab application. This is the most common of the MPI initiated events and does not require support or user interaction. It is processed automatically by the Blind Rehab application.

MPI Inquiry of Blind Rehab Patient Data:

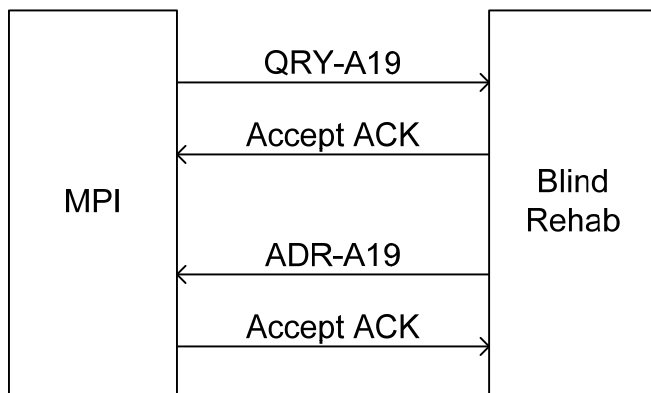

MPI may occasionally inquire about the patient information that the Blind Rehabilitation system currently has. MPI will perform this by sending a QRY-A19 message. The Blind Rehabilitation application will be responsible for querying its data and sending a pertinent response via an ADR-A19 message. The QRY-A19 and ADR-A19 messages will be one per patient. (See MPI interface spec for specific examples). Note that the QRY is sent over a socket that is created by MPI, and the Accept ACK is returned over the same socket. At this point, the socket is closed. The ADR message is then sent over a socket that is created by the Blind Rehabilitation application and the Accept ACK is returned over this socket.

Additional messages from MPI:

The Blind Rehabilitation system will simply ACK any HL7 messages sent that are not included in this document. Nothing is done in response to these messages, but an ACK will be sent in order to be compliant with the HL7 specification

Sequence Diagrams

Search Sequence (multiple records returned)

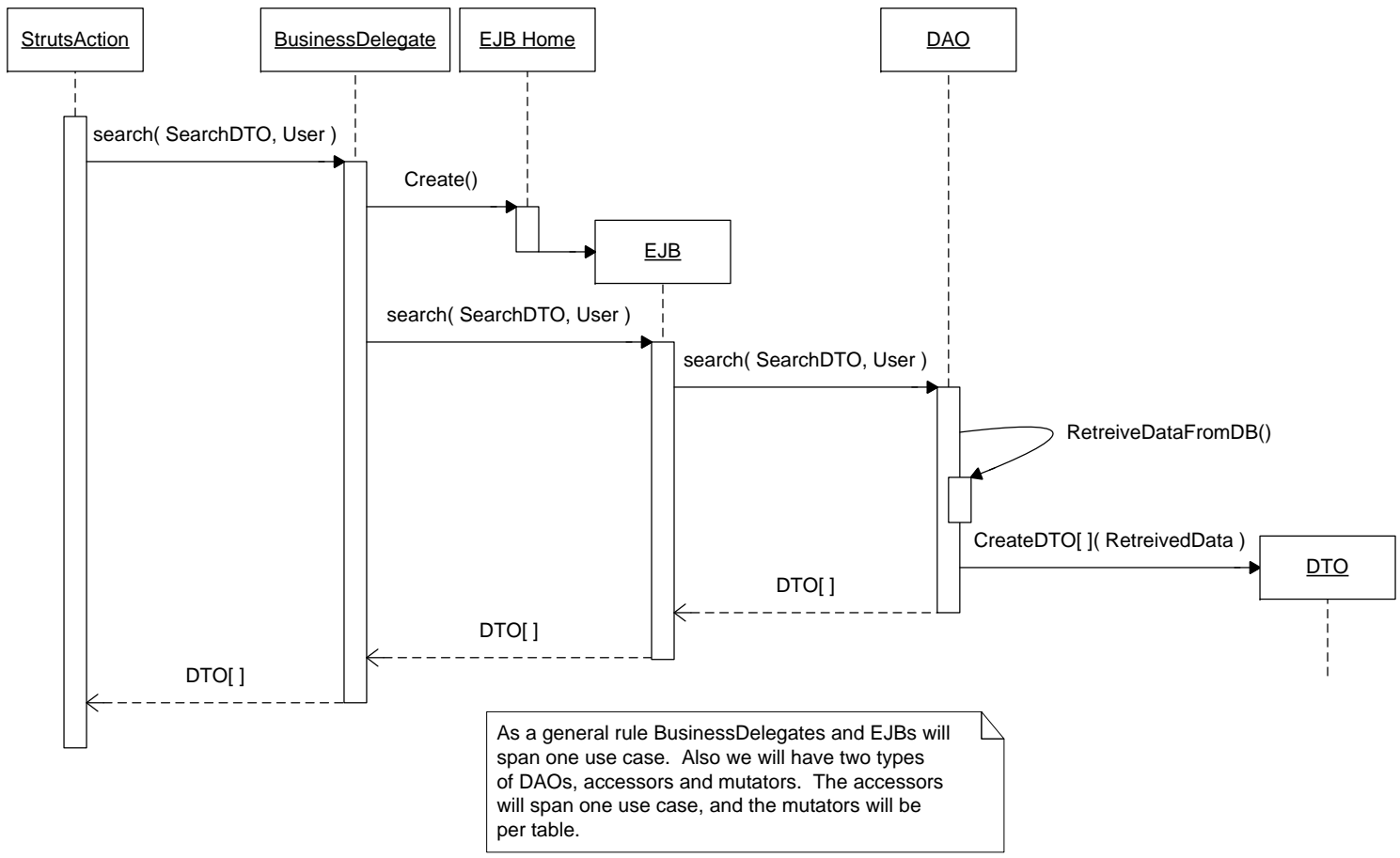

Retrieve Data Sequence (single record returned)

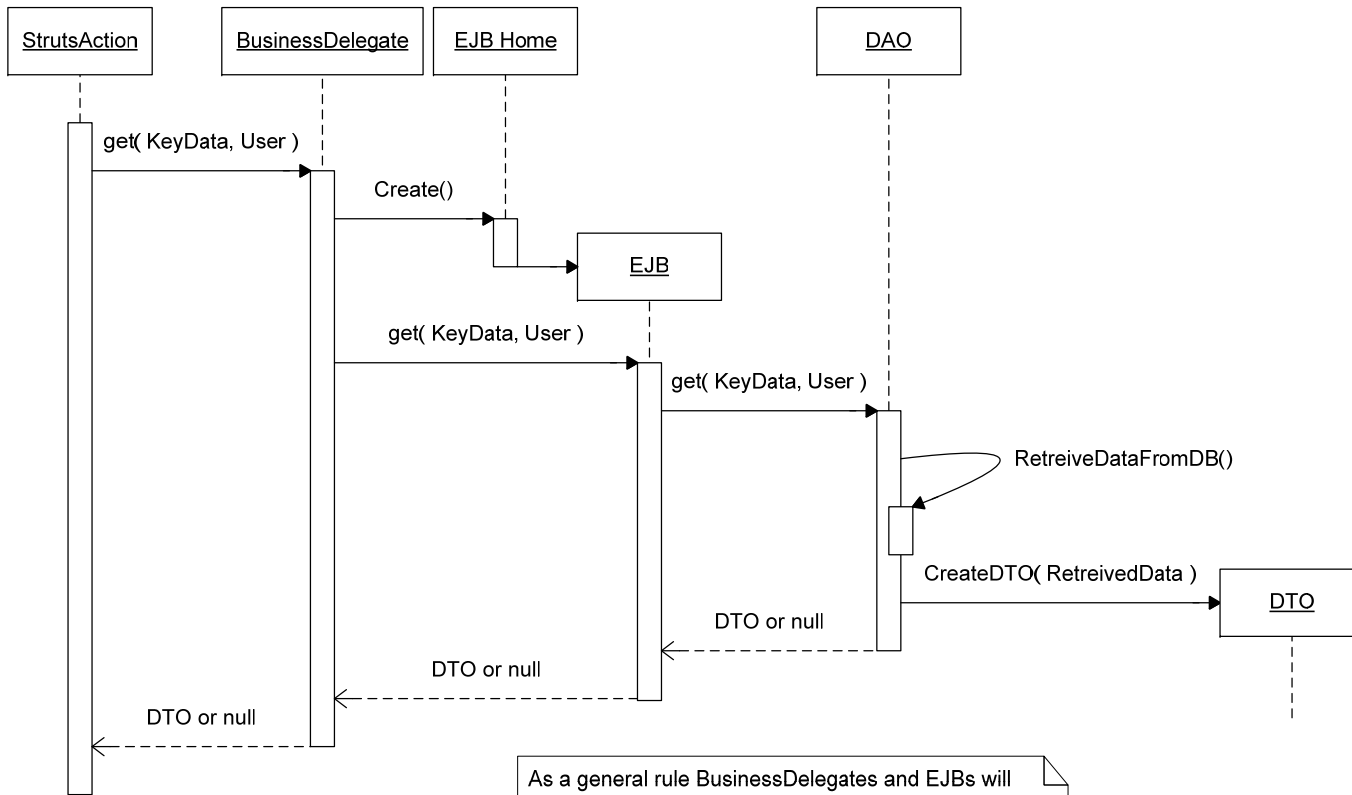

As a general rule BusinessDelegates and EJBs will span one use case. Also we will have two types of DAOs, accessors and mutators. The accessors will span one use case, and the mutators will be per table.

Store Sequence (save or update single record)

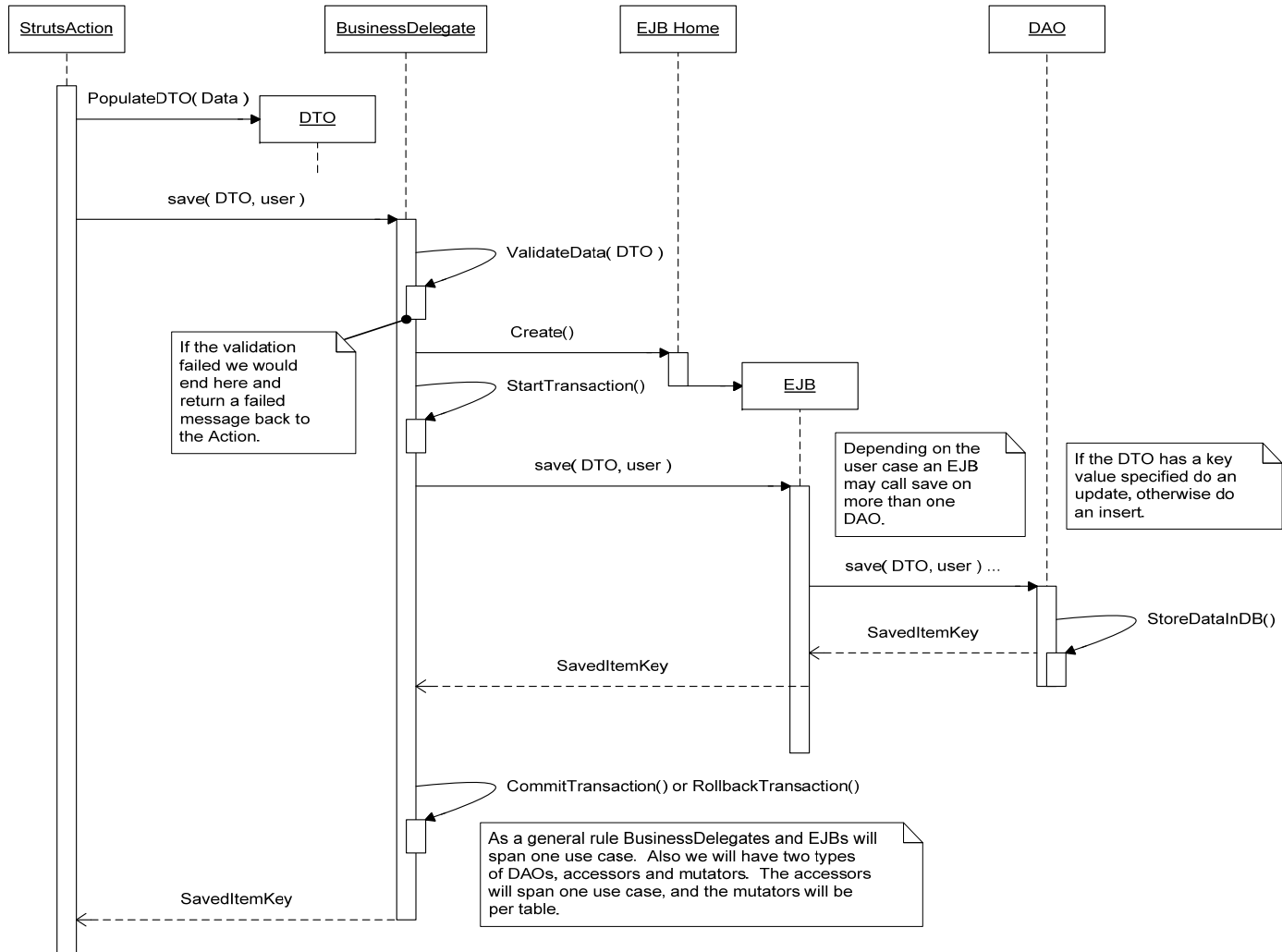

Remove Sequence (delete single record)

NOTE: No user-based functions are able to call a remove sequence.

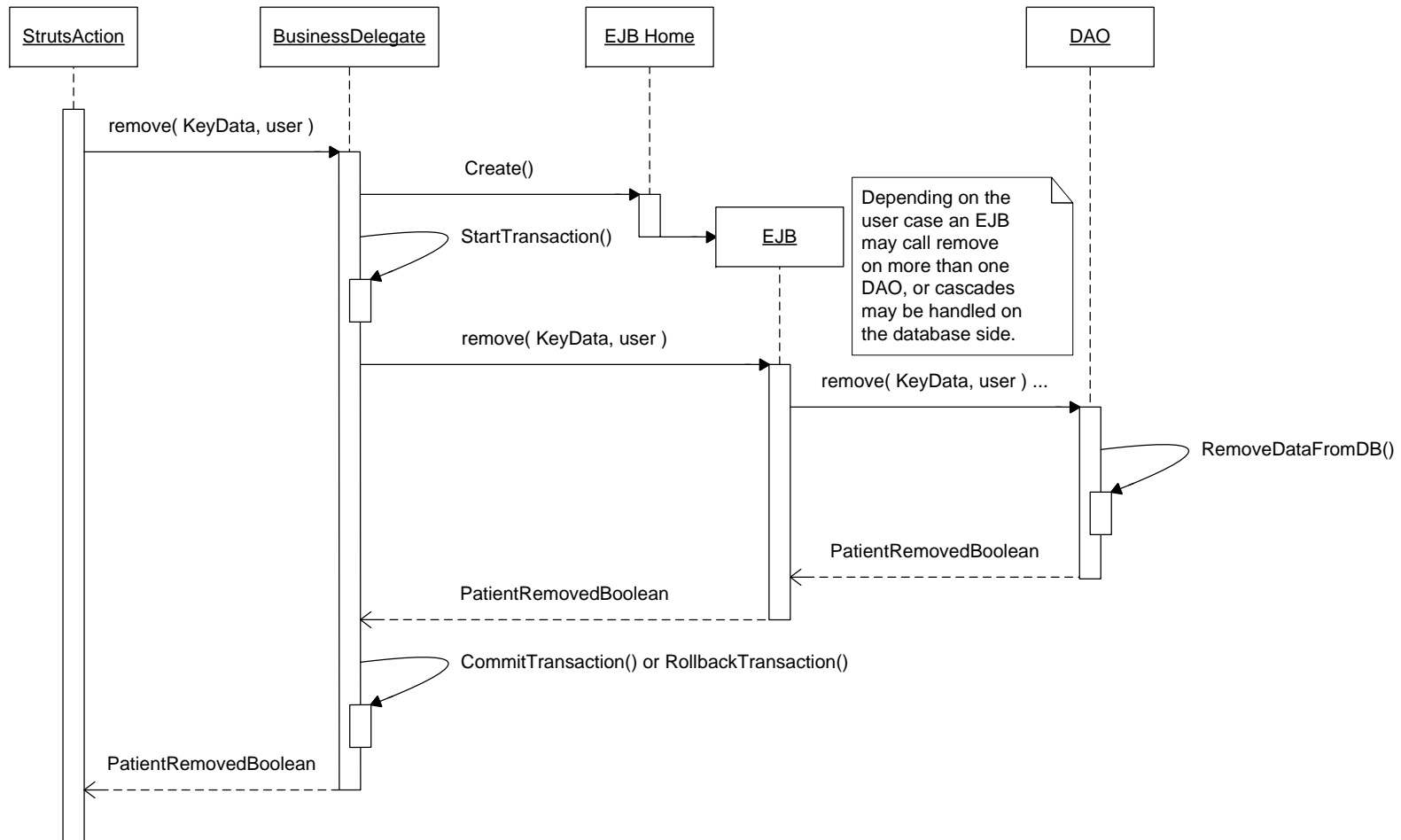

Data Conversion from Existing Applications

VIST 4.0 Data Conversion (VistA Application)

Data migration from the legacy environment to the Blind Rehabilitation 5.0 production environment will be done for each of the sites that contain VIST4.0 data. The first step that this legacy data goes through is an extraction from the VistA site to flat Oracle tables. The HDR Hx Team does this extraction. Once this extraction occurs the data will be on HDR hardware, and must be copied by the Blind Rehabilitation Team to a location where it can be used.

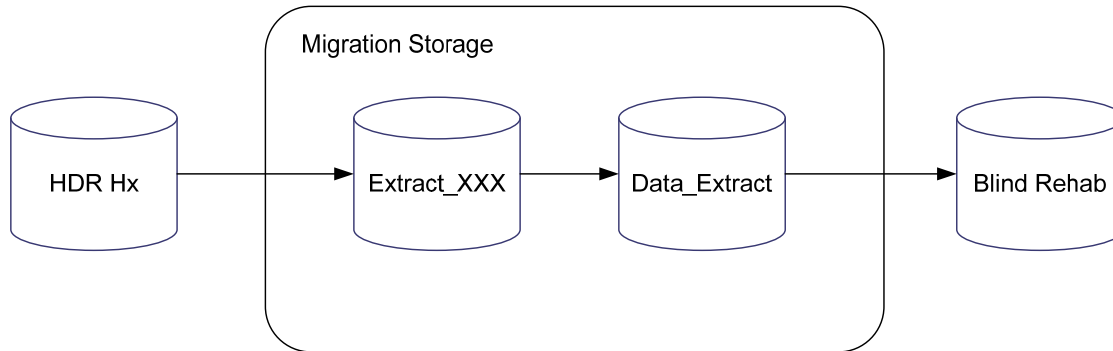

The data is copied from the HDR hardware to BR Hardware by backup scripts written in Java. These scripts copy all extracted data for a single site (Station Number). Each site will have its own extract schema (the second icon in the diagram above) this means that several sites will all be in their own schemas on the migration database.

When a site is being prepared to be migrated, it is copied into the Data_Extract schema (the third icon in the diagram above). The script that runs this copy is also written in Java. This is the schema from which the data migration scripts migrate data.

Once the data is in the Data_Extract schema it can then be migrated into a Blind Rehabilitation environment. This environment may be the production Blind Rehabilitation environment, or it may be a test environment.

Blind Rehabilitation Central Waitlist Application (Web based)

The second data source to be migrated into Blind Rehabilitation 5.0 will be from the current centralized Waitlist Application. This conversion takes a flat ASCII file named MainData.txt extracted from the central Waitlist Application and loads it as new records in the BR5 WAITLIST_SUMMARY table with the Oracle SQL Loader tool. After loading, an SQL update script is run against the table to populate missing values and convert legacy values to currently supported values.

The waitlist conversion scripts and files are located in the VSS directory: `$/Blind Rehab V5.0/Development /sql/dataConversion/`.

This conversion process only creates records in the WAITLIST_SUMMARY table and does NOT create accompanying records in the REFERRALS table as the user initiated referral functionality does. This limitation was caused by the lack of sufficient means to match uniquely the extracted waitlist records to patients in the BR database. The records are being converted to allow historical reporting and summarization of Blind Rehabilitation waitlist data.

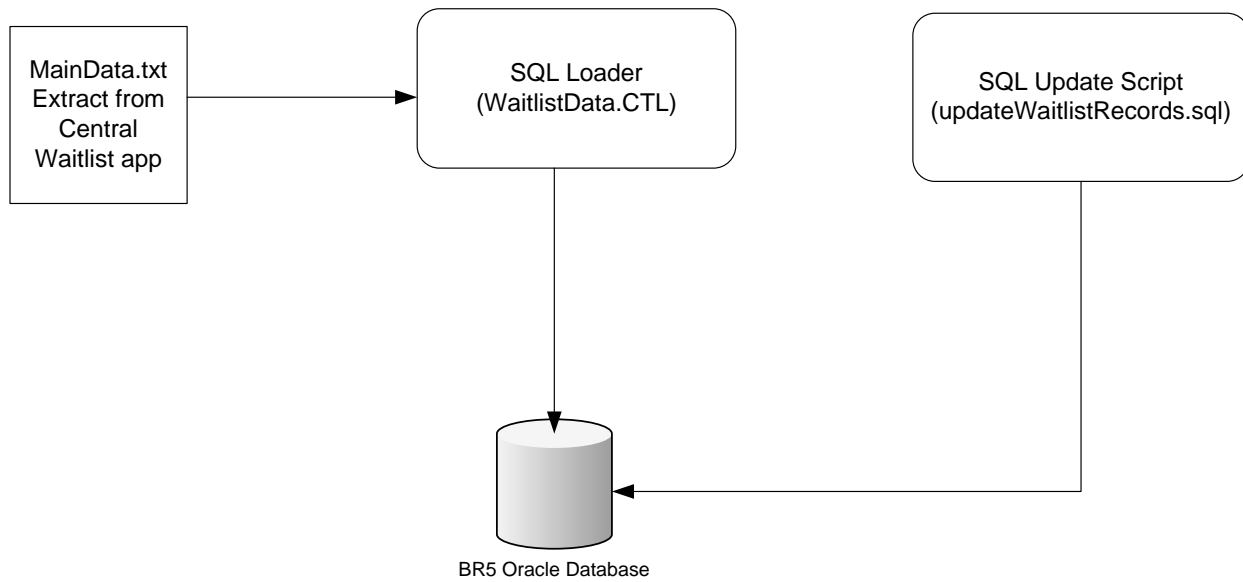

Glossary/Acronym List

<i>Term/Acronym</i>	<i>Description</i>
AAA	(Veteran Health Administration) Authentication, Authorization and Accountability Standards
AAIP	Authentication and Authorization Infrastructure Program
ADPAC	Automated Data Processing Application Coordinator
AMIS	Automated Management Information System
API	Application Program Interface
Audit Trail	A history of the changes made to a record including old data, new data, and the name of the user who made the change. Record of access and modifications
BCMA	Bar Code Medication Administration. A VistA software application that validates medications against active orders before the medication is given to the patient.
BR	Blind Rehabilitation Project
Blind Rehabilitation Center (BRC)	A residential inpatient program that provides comprehensive adjustment to blindness training and serves as a resource to a catchments area usually comprised of multiple Veterans Integrated Service Networks (VISN).
BRC Application Letter	This is a cover letter for a Blind Rehabilitation Center (BRC) Application packet. This letter requires editing and is used to print for individual veterans.
BRC Follow-up Letter	This is a questionnaire sent to the veteran following blind rehabilitation training. It is used to assist the center or clinic in following-up on the veteran.
Blind Rehabilitation Outpatient Specialist (BROS)	Blind Rehabilitation instructors possessing advanced technical knowledge and competencies in at least two Blind Rehabilitation disciplines at the journeyman level.[2]
CAT	Computer Access Training
CARF	Commission on the Accreditation of Rehabilitative Facilities
CCOW	Clinical Context Object Work Group
CCOW Term Telnet	An application (written in Delphi) which is RPCBroker aware and capable of CCOW with CCOW, which can be used to access the Roll and Scroll environment, such as List Manager, in VistA.
CCOW Timing Program	A program, written in Delphi that tests the amount of time for Remote Procedure Calls to be processed by the server.
CHISS	Common Health Information Security Services
C&P	Compensation & Pension

<i>Term/Acronym</i>	<i>Description</i>
Claim Letter	This is a cover letter to a Veterans Administration Regional Office (VARO) when filing a claim on behalf of a VIST veteran. This letter is used to print for individual veterans.
Common Procedure Terminology (CPT)	A method for coding procedures performed on a patient, for billing purposes.
CPRS	A VistA software application that provides an integrated patient record system for use by clinicians, managers, quality assurance staff, and researchers
CPRS/CCR	Computerized Patient Record System/Computerized Clinical Reminder Module
CPRS/VSM	Computerized Patient Record System/Vital Signs Module
Computerized Patient Record System (CPRS)	A clinical record system that integrates many VistA packages to provide a common entry and data retrieval point for clinicians and other hospital personnel. (CPRS). CPRS is a Veterans Health Information Systems and Technology Architecture (VistA) software application that enables clinicians, nurses, clerks, and others to enter, review, and continuously update all information connected with patients.
Context Vault	Data store that houses user sign-on credentials in a CCOW user context.
DaIS	Development and Infrastructure Support
DBIA	Data Base Integration Agreement
DELPHI	A Rapid Application Development (RAD) system/application developed by Borland International, Inc. Delphi is similar to Visual Basic from Microsoft, but whereas Visual Basic is based on the BASIC programming language, Delphi is based on Pascal.
Division	The subunit under institute has 5-6 digits/letter division ID and less than a 35 character name
EJB	Enterprise Java Bean
Encounter	A contact between a patient and a provider who has the primary responsibility of assessing and treating the patient. A patient may have multiple encounters per visit. Outpatient encounters include scheduled appointments and walk-in unscheduled visits. A clinician's telephone communications with a patient may be represented by a separate visit entry. If the patient is seen in an outpatient clinic while an inpatient, this is treated as a separate encounter.
Episode of Care	An interval of care by a health care facility or provider for a specific medical problem or condition. It may be continuous or it may consist of a series of intervals marked by one or more brief separations from care, and can also identify the sequence of care (e.g., emergency, inpatient, outpatient), thus serving as one measure of health care provided.
FSOD	Functional Status Outcomes Database

<i>Term/Acronym</i>	<i>Description</i>
Graphical User Interface (GUI)	A type of display format that enables users to choose commands, initiate programs, and other options by selecting pictorial representations (icons) via a mouse or a keyboard.
HCFA	Health Care Financing Administration
HCPCS	HCFA Common Procedure Coding System
HFS	Host File Server is a system (WinNT/Dec Alpha) file access mechanism that enables the M software (server software) to access the system-level files.
HealthVet-VistA	The HealthVet-VistA architecture will be a services-based architecture. Applications will be constructed in tiers with distinct user interface, middle and data tiers. Two types of services will exist, core services (infrastructure and data) and application services (a single logical authoritative source of data).
HIPAA	Health Insurance Portability and Accountability Act of 1996. Also referred to as, HIPAA.
HL7	Health Level Seven
HSD&D	Health Systems Design & Development
HSM	Hospital-Supplied Self Medication
HTTP	Hyper Text Transfer Protocol
HTTPS	Secured HTTP Protocol
ICD9	International Classification of Diseases 9 th Edition
ICN	Identification Control Number
IDL	Iterative Development Lifecycle
IE	Internet Explorer
IEN	Internal Entry Number
Independent Verification and Validation (IV&V)	The IV&V team supports the HSD&D mission by promoting standardization, improving software release quality and effectiveness of healthcare delivery through planned and controlled evaluation, testing, and integration of healthcare information systems. Visit the http://vista.med.va.gov/ivv/ site for additional information.
Inpatient Visit	The admission of a patient to a VAMC and any clinically significant change related to treatment of that patient. For example, a treating specialty change is clinically significant, whereas a bed switch is not. The clinically significant visits created throughout the inpatient stay would be related to the inpatient admission visit. If the patient is seen in an outpatient clinic while an inpatient, this is treated as a separate encounter.
Institution	A major hospital with subdivisions, usually has a name < 30 letters and a three-digit division ID

<i>Term/Acronym</i>	<i>Description</i>
Invitation for VIST Review	This is an invitation to blinded veterans from VIST, offering a health evaluation. Veterans may accept or deny the invitation. This letter satisfies the requirements of M-2, Part XXIII and is meant to be printed as a mass mailing.
IP	Meds Inpatient Medications
IRM	Information Resources Management
IRS Exemption Letter	This letter advises the Internal Revenue Service of legally blind status of veterans. This letter requires editing and is to be printed for individual veterans.
ISO	Information Security Officer
ISSRA	Interim Security Services for Rehosted Applications
Iterative Development	The technique used to deliver the functionality of a system in a successive series of releases of increasing completeness. Each iteration is focused on defining, analyzing, designing, building, and testing a set of requirements.
IV	Intravenous
J2EE	The Java 2 Platform, Enterprise Edition (J2EE) is an environment for developing and deploying enterprise applications. The J2EE platform consists of a set of services, APIs, and protocols that provide the functionality for developing multi-tiered, Web-based applications.
JAAS	Java Authentication and Authorization Service. For more information refer to the JAAS Web site at the following address: http://java.sun.com/products/jaas/index-14.html
JAVA	Java is a programming language. It can be used to complete applications that may run on a single computer or be distributed among servers and clients in a network.
JCAHO	Joint Commission on the Accreditation of Health Care Organizations
JDBC	Java Database Connection
JSP	Java Server Page
Kernel	Set of VistA software routines that function as an intermediary between the host operating system/application and the VistA application packages such as Laboratory, Pharmacy, IFCAP, etc. The Kernel provides a standard and consistent user and programmer interface between application packages and the underlying M implementation.
Kiosk	Public workstations shared by multiple users.
List Manager	A VistA software product that creates a framework for user actions. List Manager is part of the VistA software infrastructure.
LOINC	Logical Observation Identifier Names and Codes
MAH	Medication Administration History
MAS	Medical Administration Service

<i>Term/Acronym</i>	<i>Description</i>
MH Assistant	Mental Health Assistant
MPI	Master Patient Index
MST	Military Sexual Trauma
MTAS	Middle Tier WebLogic Application Server
MVC	Model View Controller
New Person (#200) File	A VistA file that contains data on employees, users, practitioners, etc. of the VA.
NOIS	National Online Information System
NVS	National VistA Support
O-R	Object-Relational
OCS	VA Office of Cyber Security
OID	Oracle Internet Directory
ORACLE	Oracle is a relational database that supports the Structured Query Language (SQL), now an industry standard.
ORACLE 9iAS	Oracle 9i Application Server
PATS	Patient Advocate Tracking System/application. When completed, the Patient Advocate Tracking System/application will replace the current, site-based Patient Representative package with a national level application.
PCE	Patient Care Encounter
PIMS	Patient Information Management System
PIR	Patient Incident Review File
PLU	Patient Lookup
PSC	Patient Service Construct
PSD	Patient Service Demographics
PSL	Person Service Lookup
PRN	Pro Re Nata, Latin meaning 'as needed'
Prototype	An initial working model as proof of concept of a product or new version of an existing product.
Provider	The entity that furnishes health care to consumers. An individual or defined group of individuals who provide a defined unit of health care services (defined = codable) to one or more individuals at a single session.
PTF	Patient Treatment File (PTF) at AAC
RDBMS	Relational Database Management System

<i>Term/Acronym</i>	<i>Description</i>
Registration	Registration File
RN	Registered Nurse
ROES	Remote Order Entry System
SAS	SAS is a company that provides data analysis, data mining, and data storage
ScreenMan	VA FileMan utility that provides a screen-oriented interface for editing and displaying data
SDD	Software Design Document
SQA	Software Quality Assurance
SDS	Standard Data Service
SRS	Software Requirements Specifications
SSL	Secure Socket Layer
SSO	Single Sign On
TCP/IP	Transmission Control Protocol/Internet Protocol
Thin-client	A simple client program, which relies on most of the function of the system being in the server, usually the Web browser in a Web domain
TIU	Text Integration Utility
User	An Administrator, a Clinician, or a Researcher
VA	Veterans Affairs
VA FileMan	VistA database management system.
VAMC	Veterans Affairs Medical Centers
VARO	Veterans Administration Regional Office
VHA	Veterans Health Administration
VISN	Veterans Integrated Service Network
VIST	Visual Impairment Service Team
VistA	Veterans Health Information Systems and Technology Architecture
VistA MailMan	VistA electronic mail system

Index

Blind Rehabilitation Application	16	Development Projects	25
Application Property Files	21	Development Tools	
EJB Archive File	20	Ant	25
Enterprise Archive	16	Chainsaw	25
APP-INF Directory	16	Libraries	25
Application.xml	16	Log4j	25
Weblogic-application.xml	16	Development Tools.....	25
Exceptions.....	22	HealthVet Services	26
Other Configuration Files	21	KAAJEE	26
Service Imports	22	PSC (formerly PSD)	26
Struts Config Files	19	PSL	26
Web Archive File	18	SDS	26
Directory Contents	18	VJL	26
Web Archive web.xml File	19	Orientation.....	4
Web Archive Weblogic.xml File	19	Documentation Retrieval	5
Business Rule Implementation	27	Recommended Users	4
Concurrency	29	Related Manuals	4
Data Validation	27	VistA Intranet	5
Data Validation – Business Layer.....	27	Parameter Definition.....	10
Data Validation – Control Layer.....	27	Remote Procedure.....	10
Data Validation – Model Layer	28	Required Builds	10
MPI Interaction	29	Revision History	i
Notifications.....	28	Routines.....	8
Overnight Processing	29	Security Keys.....	8
Site Parameters.....	29	Security Management	13
Transactions	28	Application Security	14
Web Security.....	27	Archiving/Purging	15
Data Conversion from Existing Applications.....	41	Audit Trail	14
Blind Rehabilitation Central Waitlist		Contingency Planning.....	15
Application (Web based)	41	Electronic Signatures.....	15
VIST 4.0 Data Conversion (VistA		File Security.....	15
Application.....	41	Official Policies	15
Database Integration Agreements (DBIAs).....	12	Reference	15
Exported VistA Options	9	Remote Systems	14
External Interfaces.....	11	Security Keys.....	15
Implementation and Maintenance		Strategic Initiatives Overview	14
BR Production Centralized Server		Sequence Diagrams	37
Deployment.....	6	Remove Sequence (delete single record).....	40
BR Sample Configuration.....	7	Retrieve Data Sequence (single record	
Implementation and Maintenance.....	5	returned).....	38
Index	49	Search Sequence (multiple records returned)	
Introduction	1	37
Benefits	2	Store Sequence (save or update single record)	
Enhanced Technology.....	2	39
Vista Software Requirements.....	3	Software Product Security	13
Java Enterprise Developer Workstation	24	VistA Files.....	8
Development Platform	24		